

ORAMA MINIMAL FRAMES ARCHITECTURAL CATALOGUE





Orama Architectural Catalogue

Edition 4.0 / 11 · 2017

First Edition 10 · 2014

Technical drawings: **Orama R & D**

Catalogue design: **Role Play** / roleplay.gr

Request digital drawings by contacting us

at info@oramaminimalframes.com

or visit www.oramaminimalframes.com/downloads

2	Introduction
3	Technical sheet
4	OMICRON
4.1	Typical Sections
4.2	Multitrack Frames
4.3	Labyrinth Profiles
4.4	Glass Combinations
5	ΩMEGA
5.1	Typical Sections
5.2	Multitrack Frames
5.3	Labyrinth Profiles
5.3	Glass Combinations
6	Handle
7	Motorization
8	Locking devices
9	Base Sections
9.1	Invisible base
10	Installation Mode
11	Main frame solutions
11.1	F Fix
11.2	FF Double Fix
11.3	SS Double Sliding
11.4	SF Sliding Fix
11.5	Pocket single track
11.6	Pocket double track
11.7	FSSF Sliding on different track
11.8	FSSF Sliding on same track
11.9	FSF Fix · Sliding · Fix
11.10	SSF Double Sliding · Fix
11.11	SSS Triple Sliding
11.12	FSFSF Fix · Sliding · Fix · Sliding · Fix
11.13	F+F Fixed corner
11.14	FF+FF Double fixed corner
11.15	FS+SF Open corner sliding inside
11.16	FS+SF Open corner sliding outside
12	Wind load diagrams
13	Thermal performanc

INTRODUCTION

2

A completely new system has been elaborated, based on a 20-year experience in aluminum profiles, meeting the highest standards in elegance, comfort and performance.

The system offers the excellent **Uw values** with double and triple glazing which meet the demands of the most critical environments.

All sliding typologies are available including **single, double, and triple track systems** as well as **corner-free** solutions that open your vision to 360 degrees.

The **high capacity stainless steel rollers and tracks** allow smooth sliding action and extreme ease of movement with large glass areas.

Concealed **electric drives and locks** can be used to increase operating comfort and to increase the security level of the opening.

The aluminium windows can be **fully integrated into the wall, ceiling and floor**, which results in a completely invisible frame and increased vision to the outside environment.

The high-quality multi-locking point system developed by ORAMA offers the best possible **burglar resistance** in accordance with European standards.

A new evolution has been created in the concept of drainage, increasing the speed of draining away water.

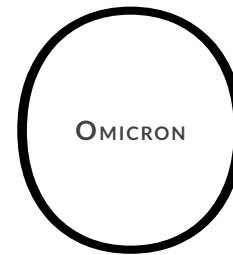



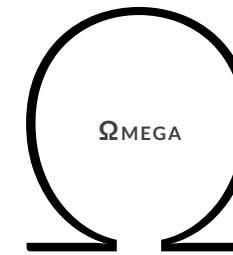







OMICRON is our standard minimal frames system incorporating all the significant features of the Orama system in a double-glazed setup.



ΩMEGA is an advanced minimal frames system able to deliver higher insulation performance and bigger sizes through thicker triple glazing.



	OMICRON	ΩMEGA	
Facing width	24 - 30mm	24 - 30mm	
Installation flush to the floor	yes	yes	
Installation flush to the ceiling	yes	yes	
Max. leaf height	4.5m	6.5m	
Max. leaf width	3m	3m	
Max. leaf weight	500kg	1000kg	
Max. sliding leaf area	12m ²	16m ²	
Max. fix leaf dimension	18m ²	21m ²	
Motorization	yes	yes	
“Invisible” railing	no	no	
Glass thickness	30 - 36 mm	46 - 54 mm	

· THE ORAMA CERTIFICATES ·

Uw values (depending on glass type & dimension)		From 0,7 to 1,7 W/m ² K
Air permeability		EN 12207 : Class 4
Resistance to rain penetration		EN 12208 : Class 7A
Resistance to wind loads		EN 12210 : Class C5
Sound insulation		up to 42 dB DIN EN ISO 140-3:2005
Resistance to burglary		ENV 1627 WK-2/RC-2 (under testing)
Accessibility		DIN 18040-2 (under testing)

OMICRON • TYPICAL SECTIONS

4.1

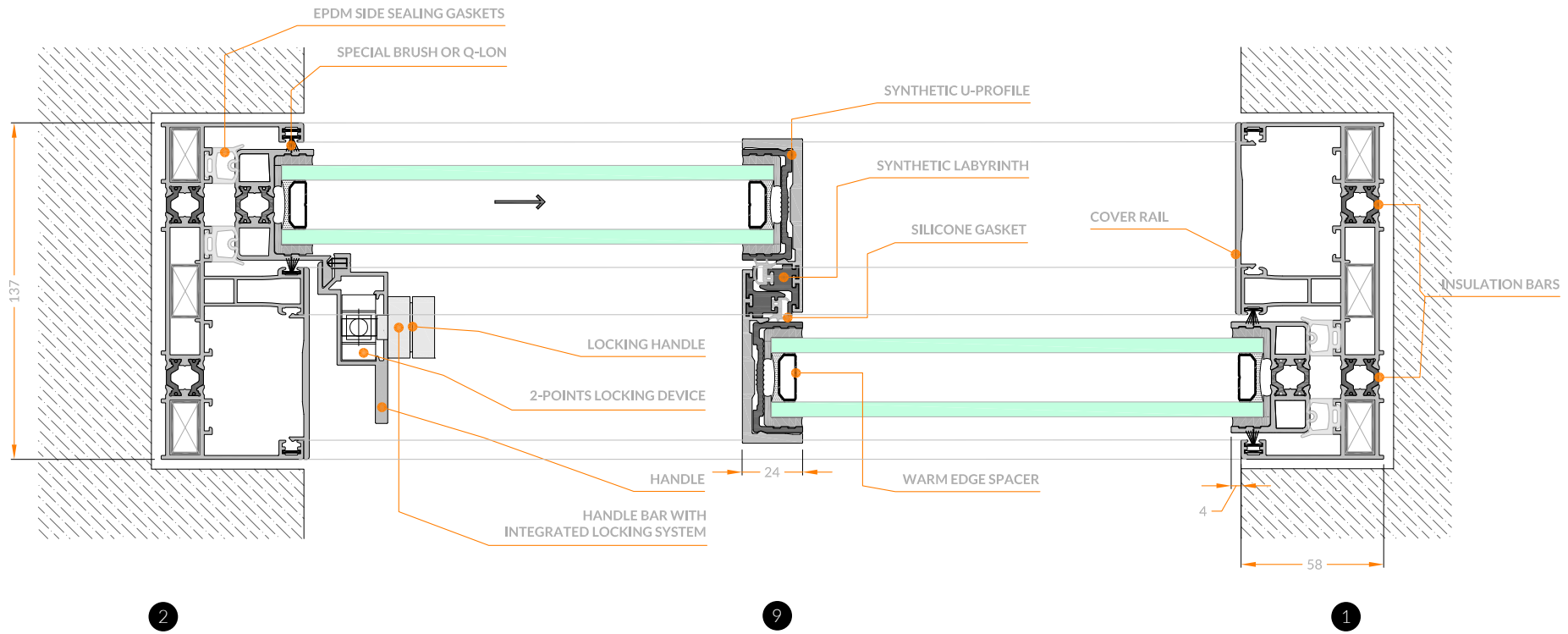

HORIZONTAL SECTION

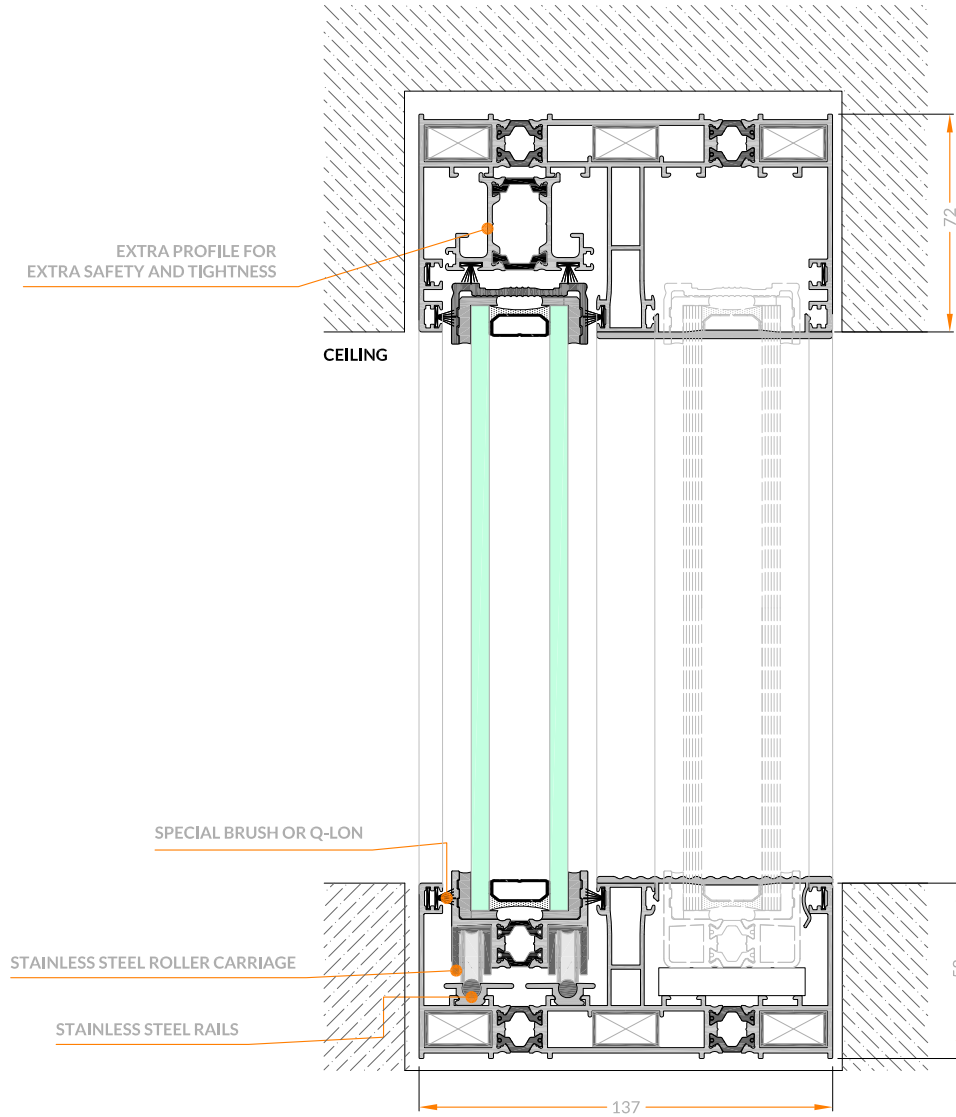

VERTICAL SECTION

OMICRON • MULTI-TRACK FRAMES

4.2

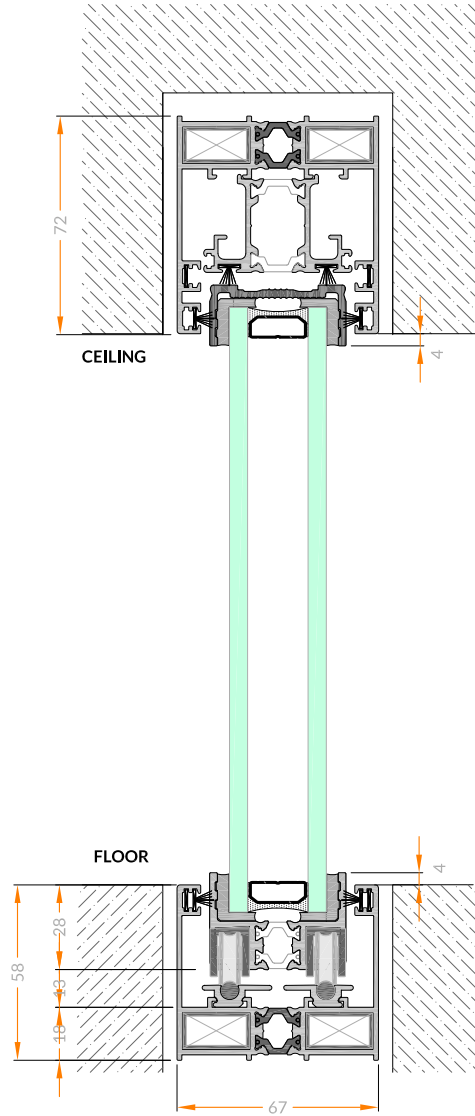

SINGLE TRACK FRAME • SLIDING • FIX

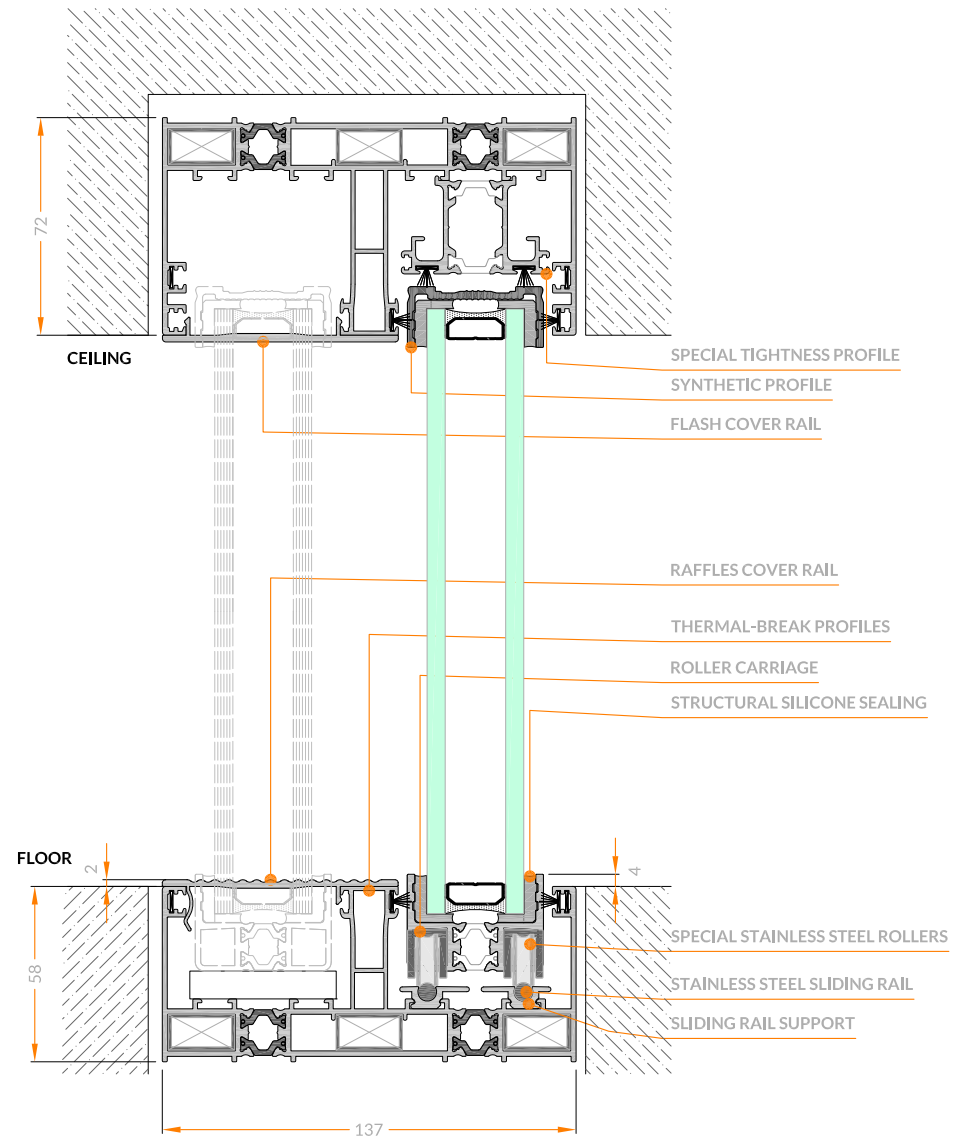

DOUBLE TRACK FRAME • SLIDING • FIX

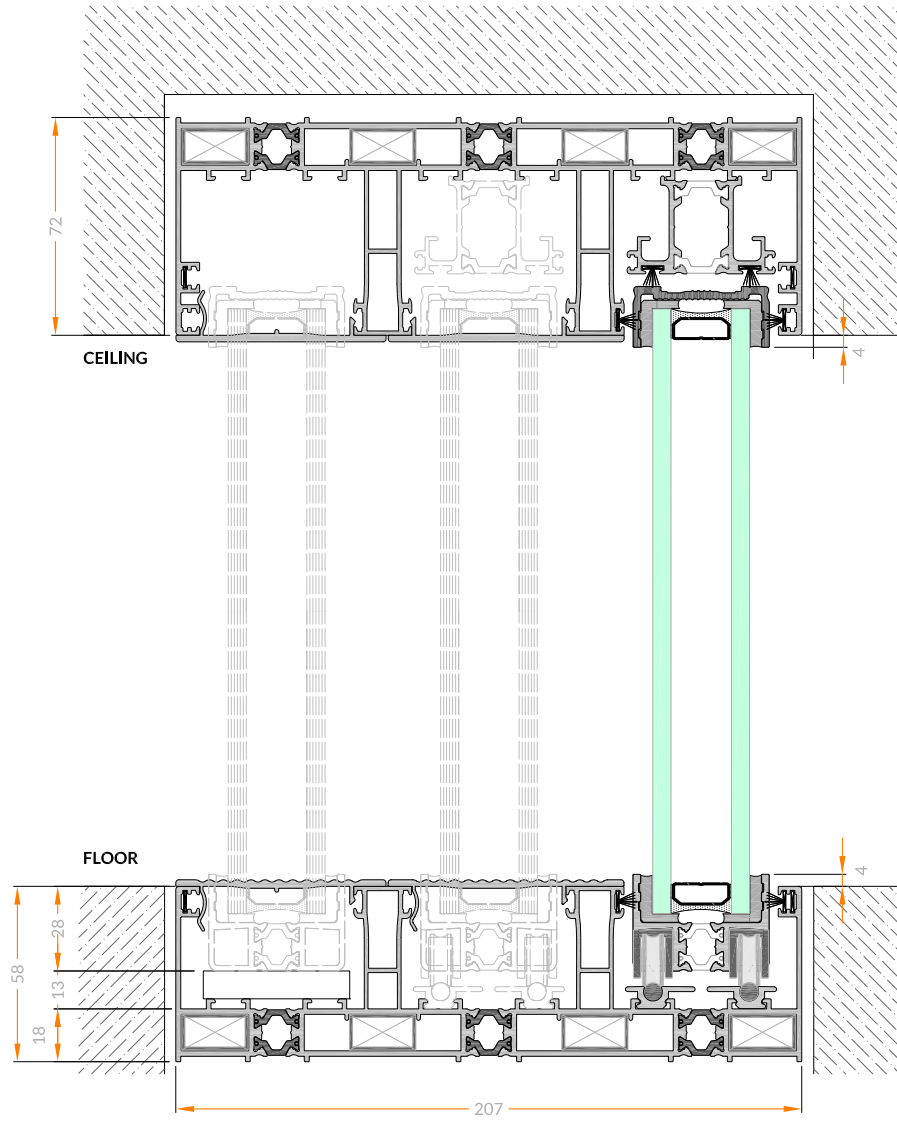

TRIPLE TRACK FRAME · S · S · F

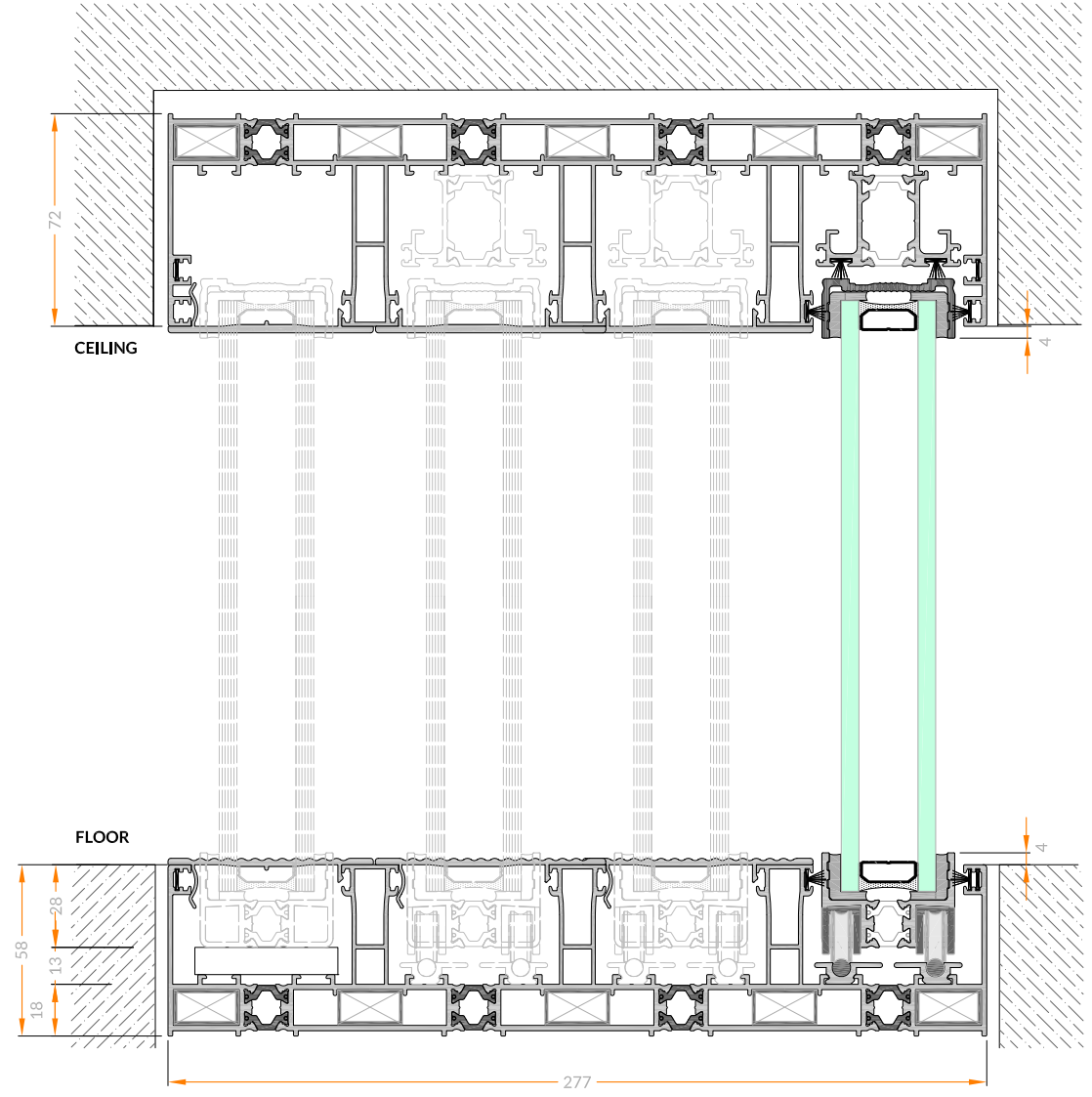

QUADRUPLE TRACK FRAME · S · S · S · F

OMICRON • LABYRINTH PROFILES

4.3

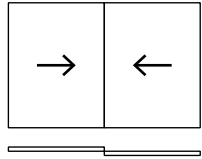

Standard sliding frames (different track)

A

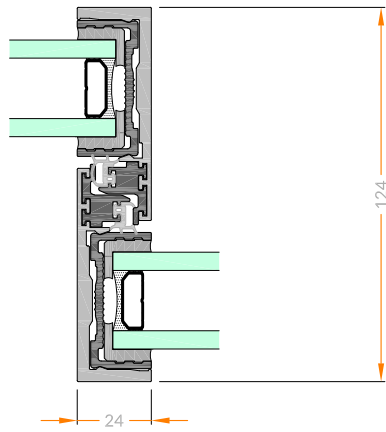

9

Steel reinforcement when statically required

B

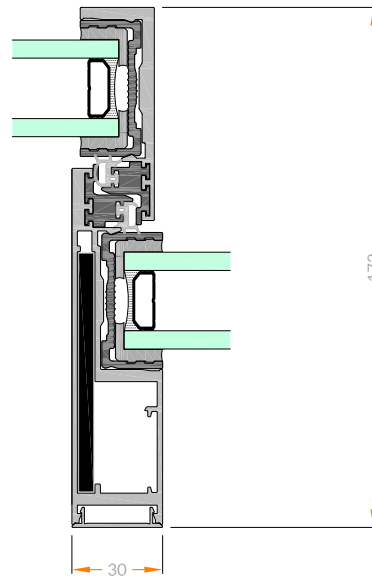

10

C

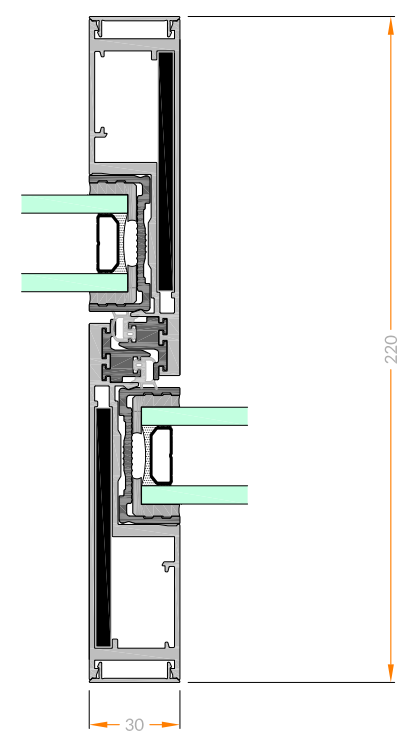

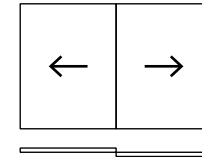

Sliding away
from each other
(different track)

4.3

E

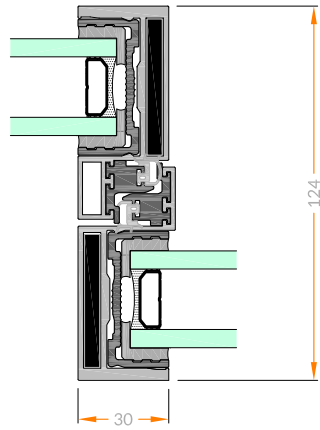

D

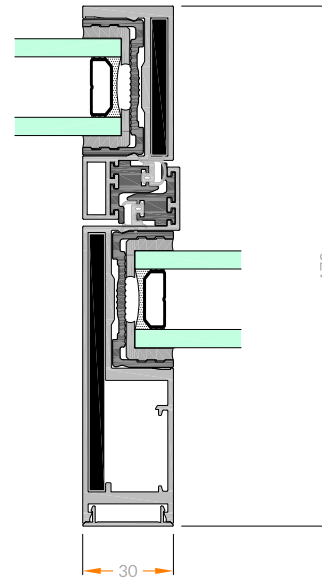

F

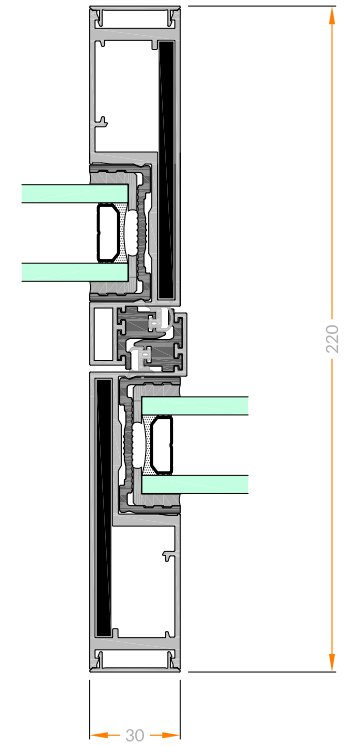

Steel reinforcement
when statically required

12

OMICRON • GLASS COMBINATIONS (from 30mm - max 36mm)

4.4

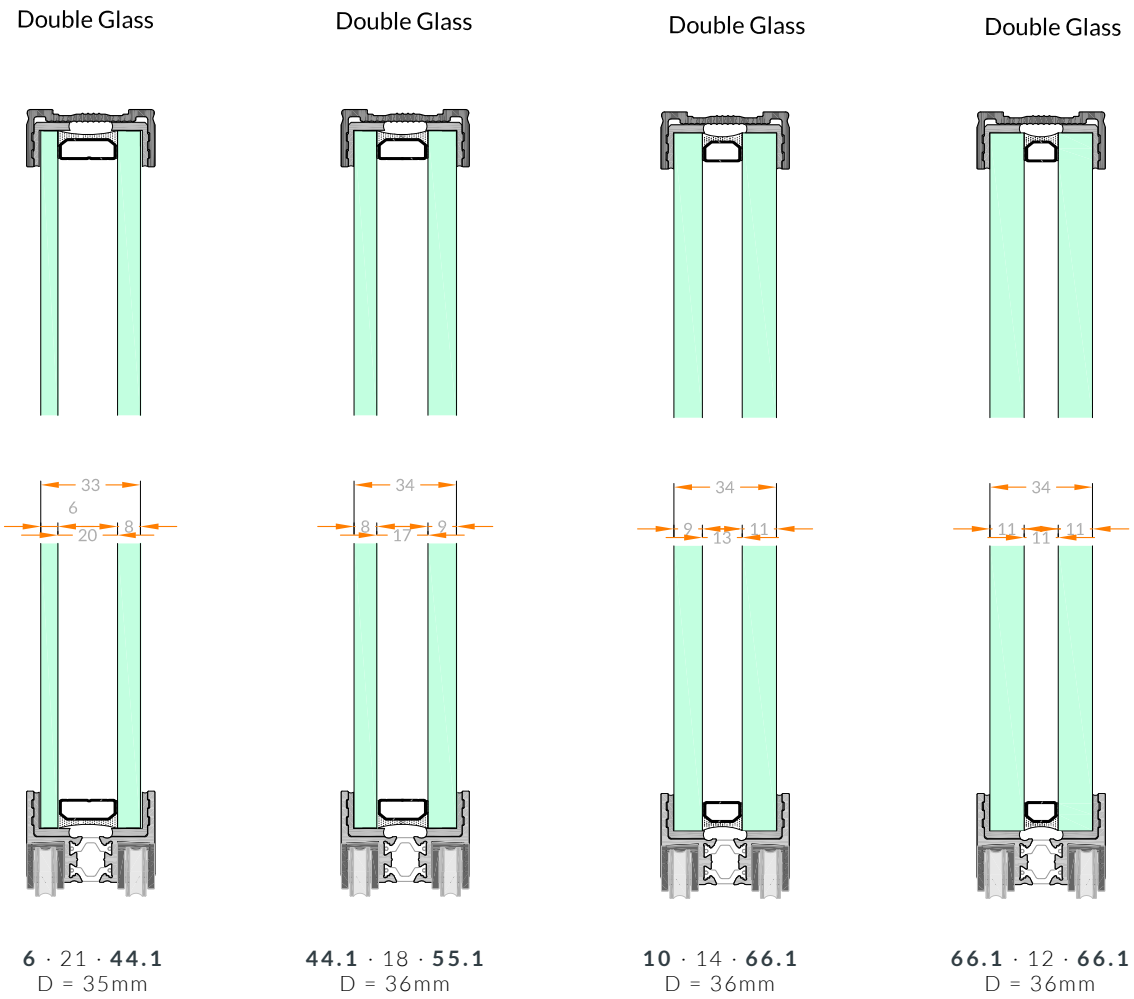

VERTICAL SECTIONS

HEAT MIRROR GLASS

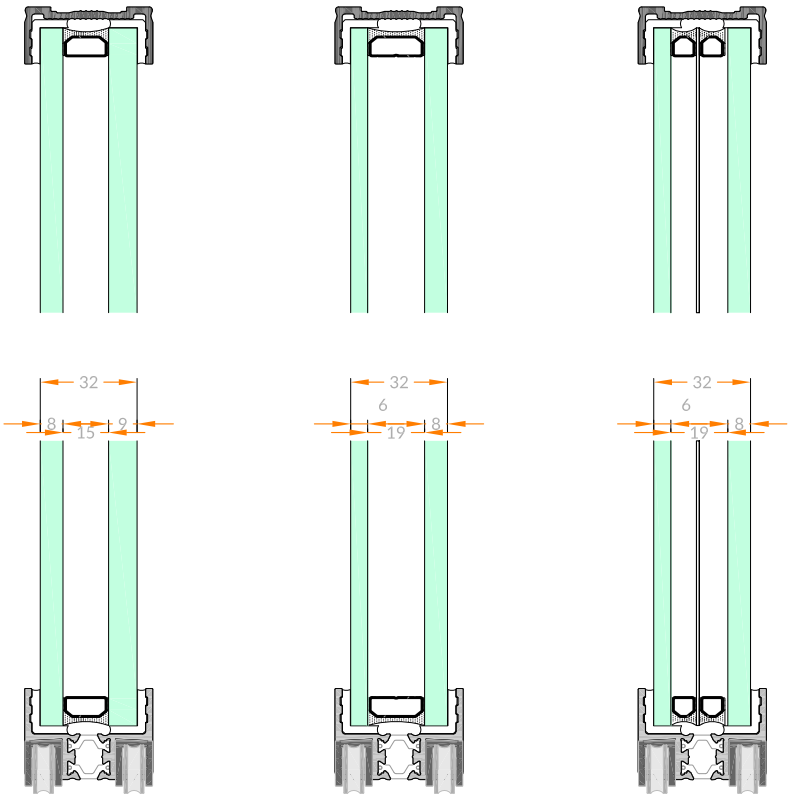

44.1 · 16 · 10
D = 34mm

6 · 20 · 44.1
D = 34mm

6 · 9 · HM · 9 · 44.1
D = 34mm

VERTICAL SECTIONS

ΩMEGA • TYPICAL SECTIONS

5.1

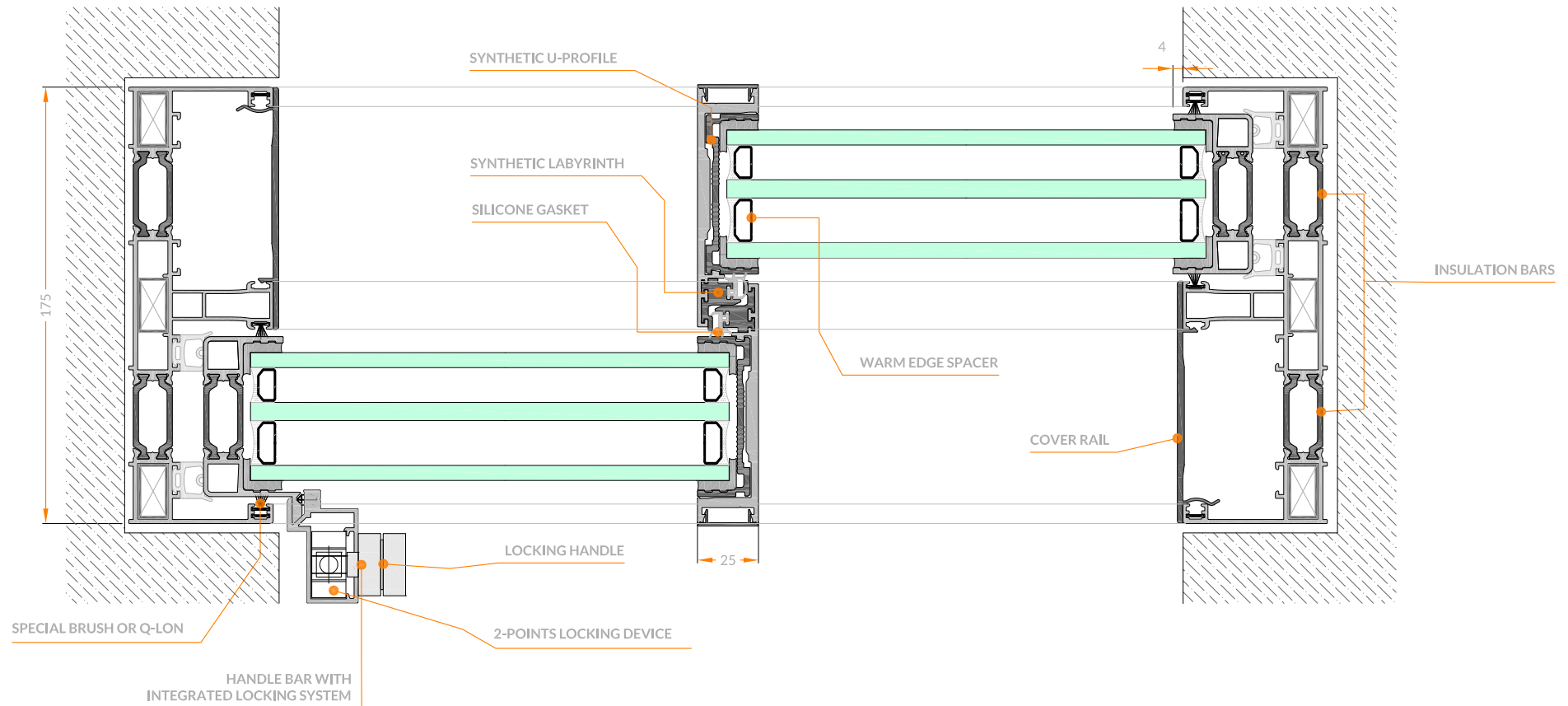

HORIZONTAL SECTION

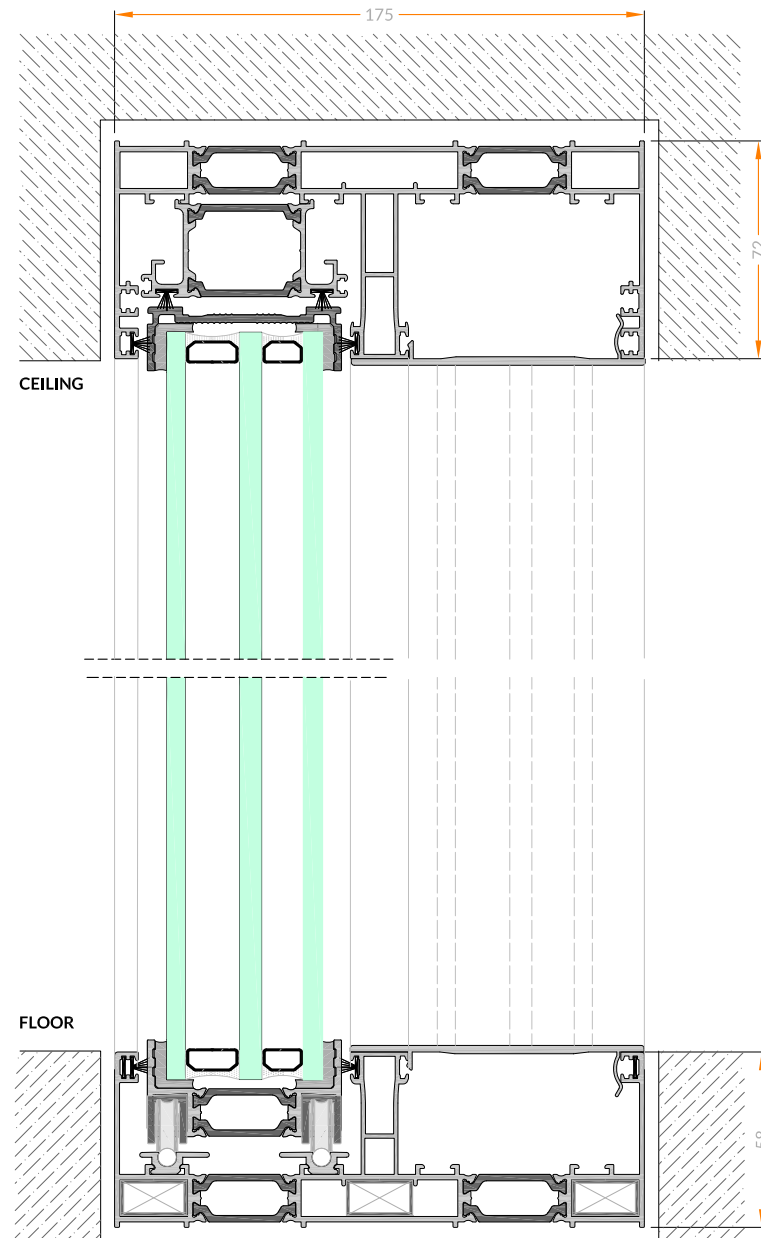

VERTICAL SECTION

5.2

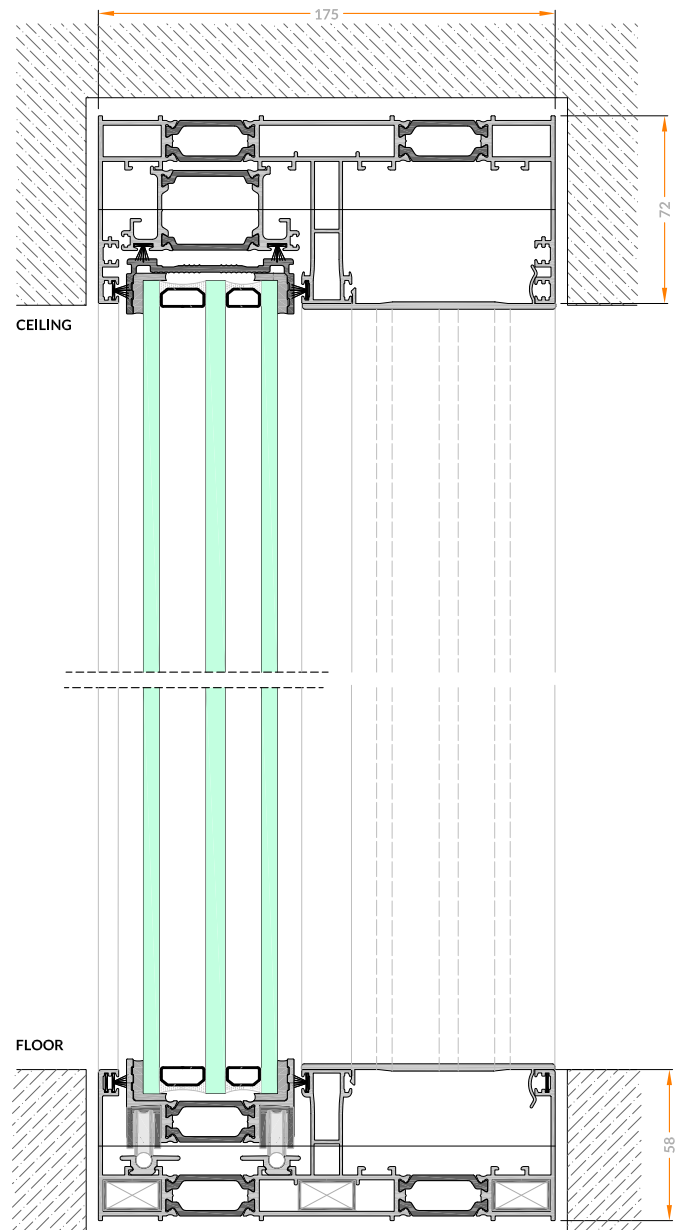
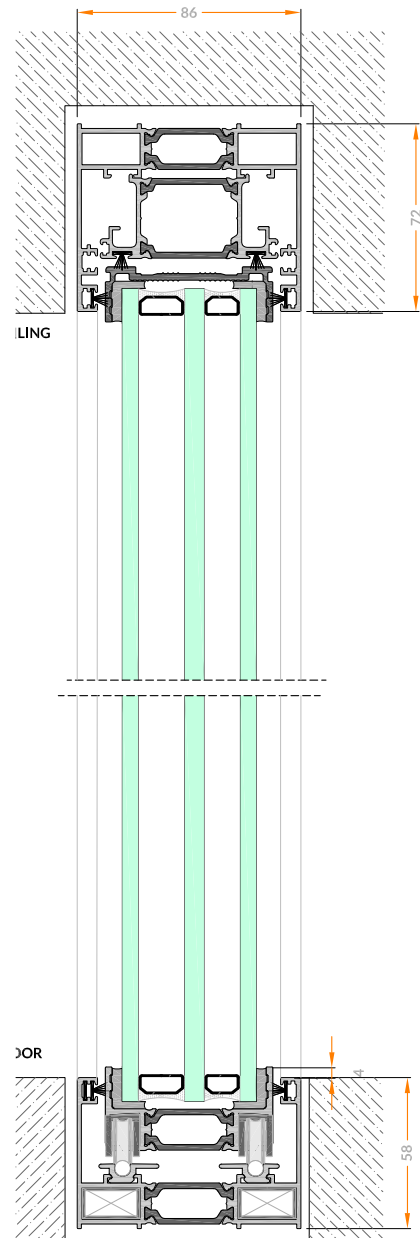

VERTICAL SECTIONS

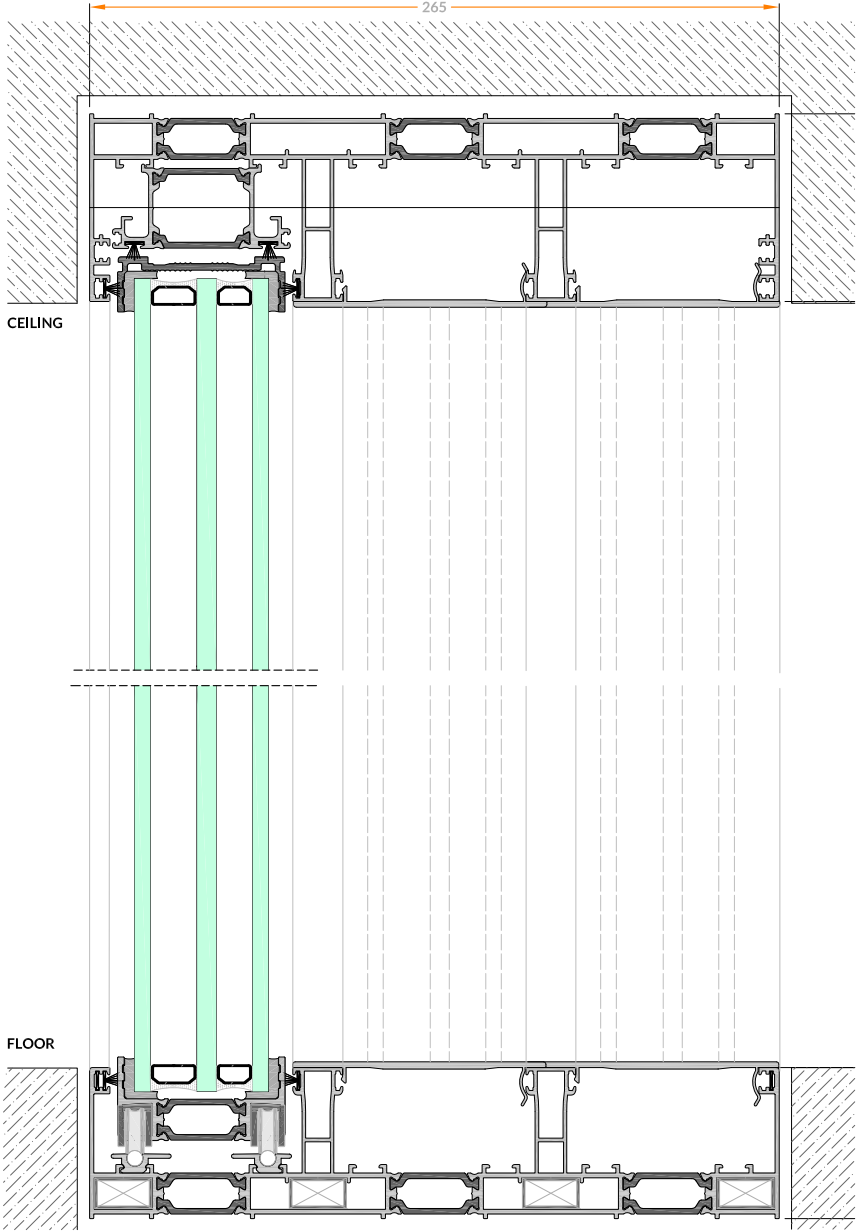

VERTICAL SECTION

5.3

A

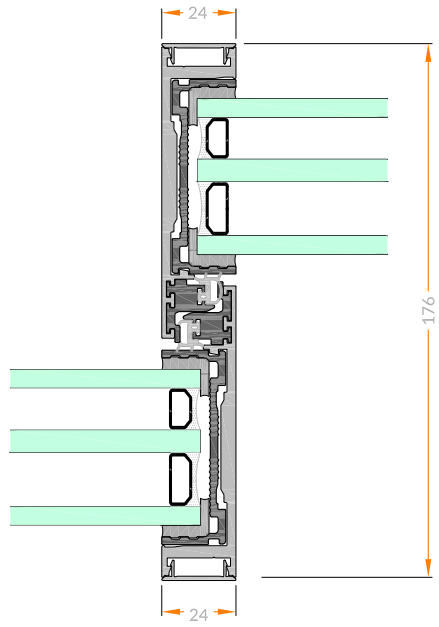

B

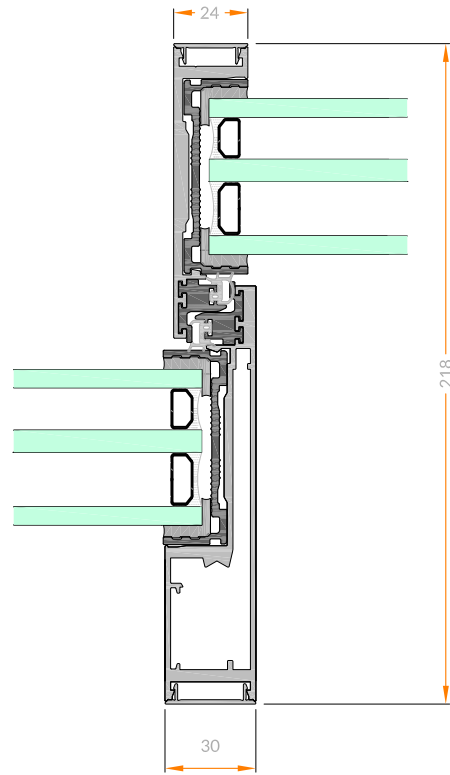

C

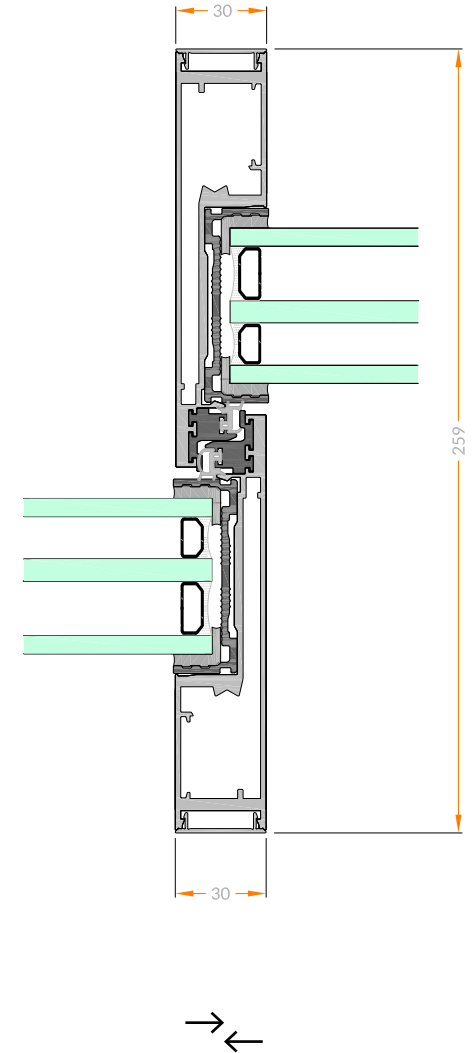

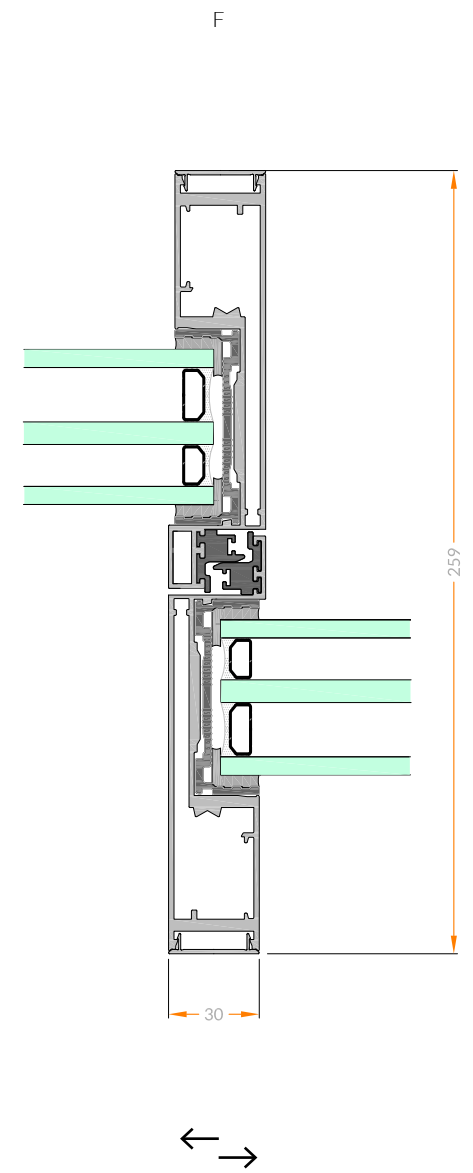
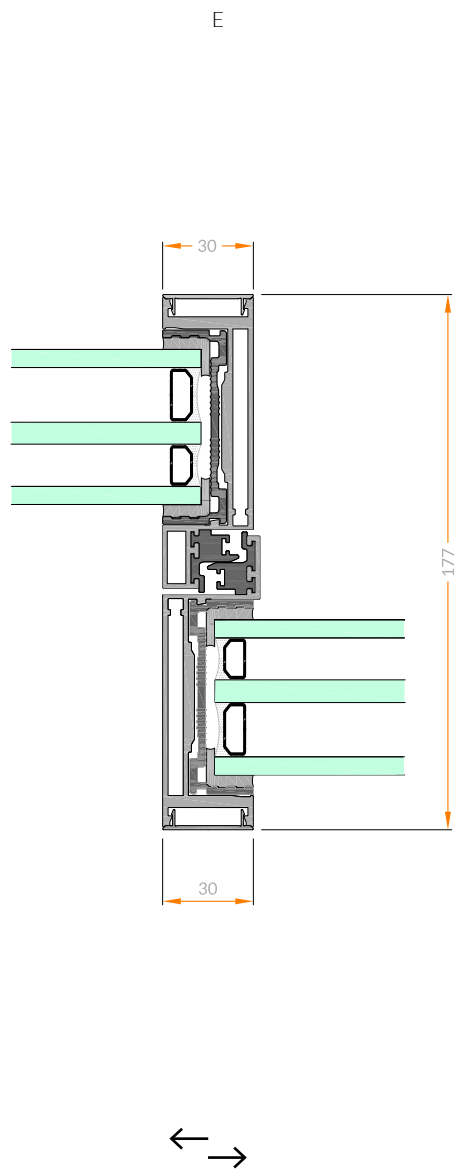
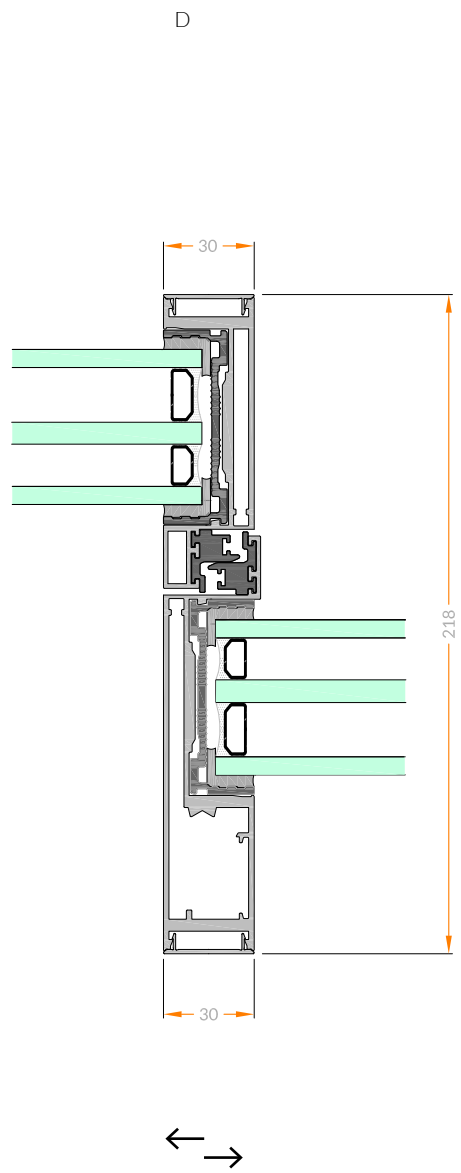

ΩMEGA • GLASS COMBINATIONS (from 49mm - max 54mm)

5.4

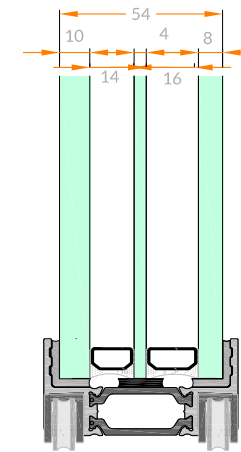
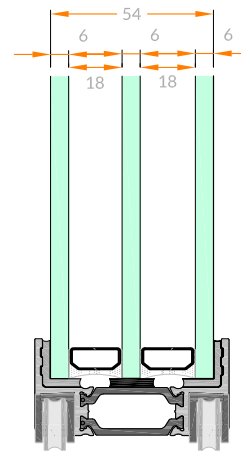
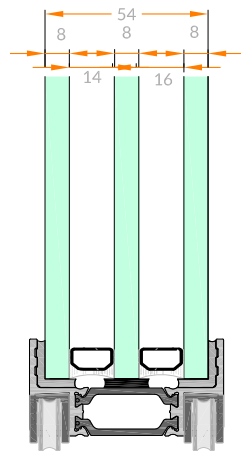
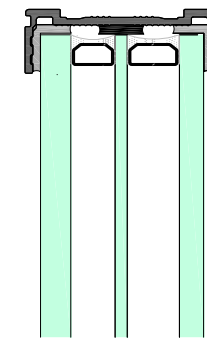
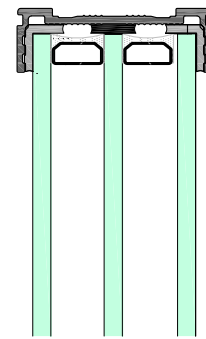
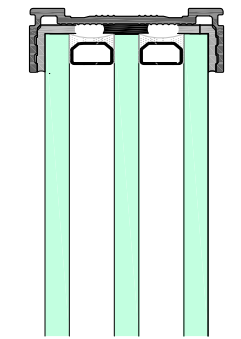

8 · 14 · 8 · 16 · 8
D = 54mm

6 · 18 · 6 · 18 · 6
D = 54mm

10 · 14 · 4 · 14 · 8
D = 54mm

VERTICAL SECTIONS

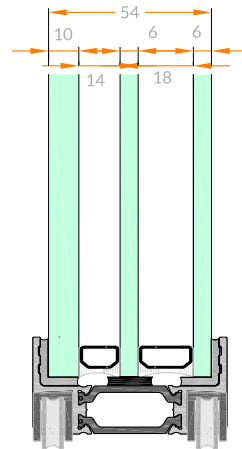
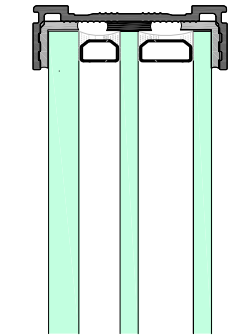

10 · 14 · 6 · 18 · 6
D = 54mm

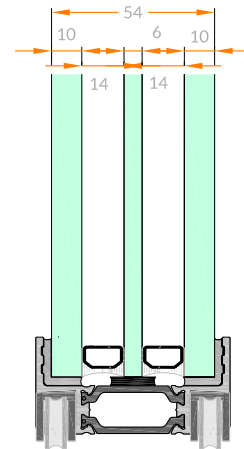
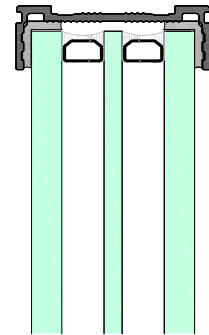

10 · 14 · 6 · 14 · 10
D = 54mm

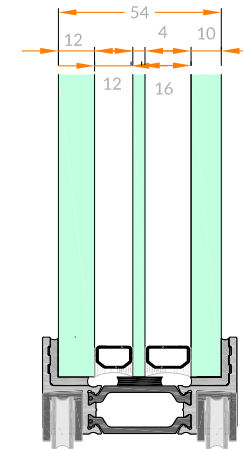
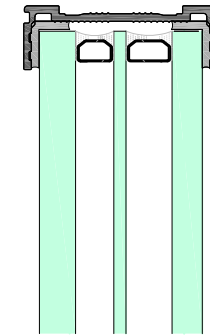

12 · 12 · 4 · 16 · 10
D = 54mm

HANDLE

6

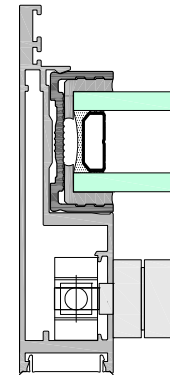
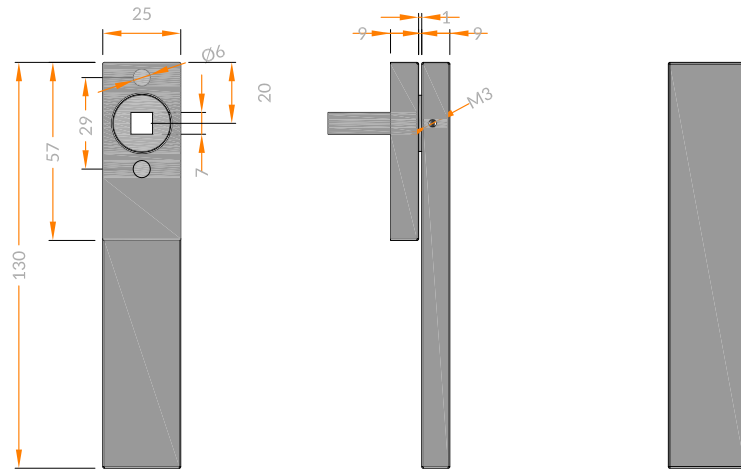
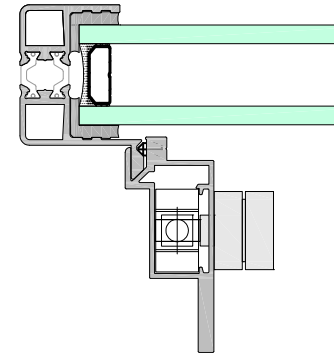
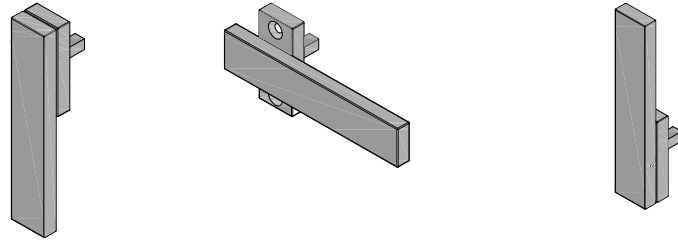

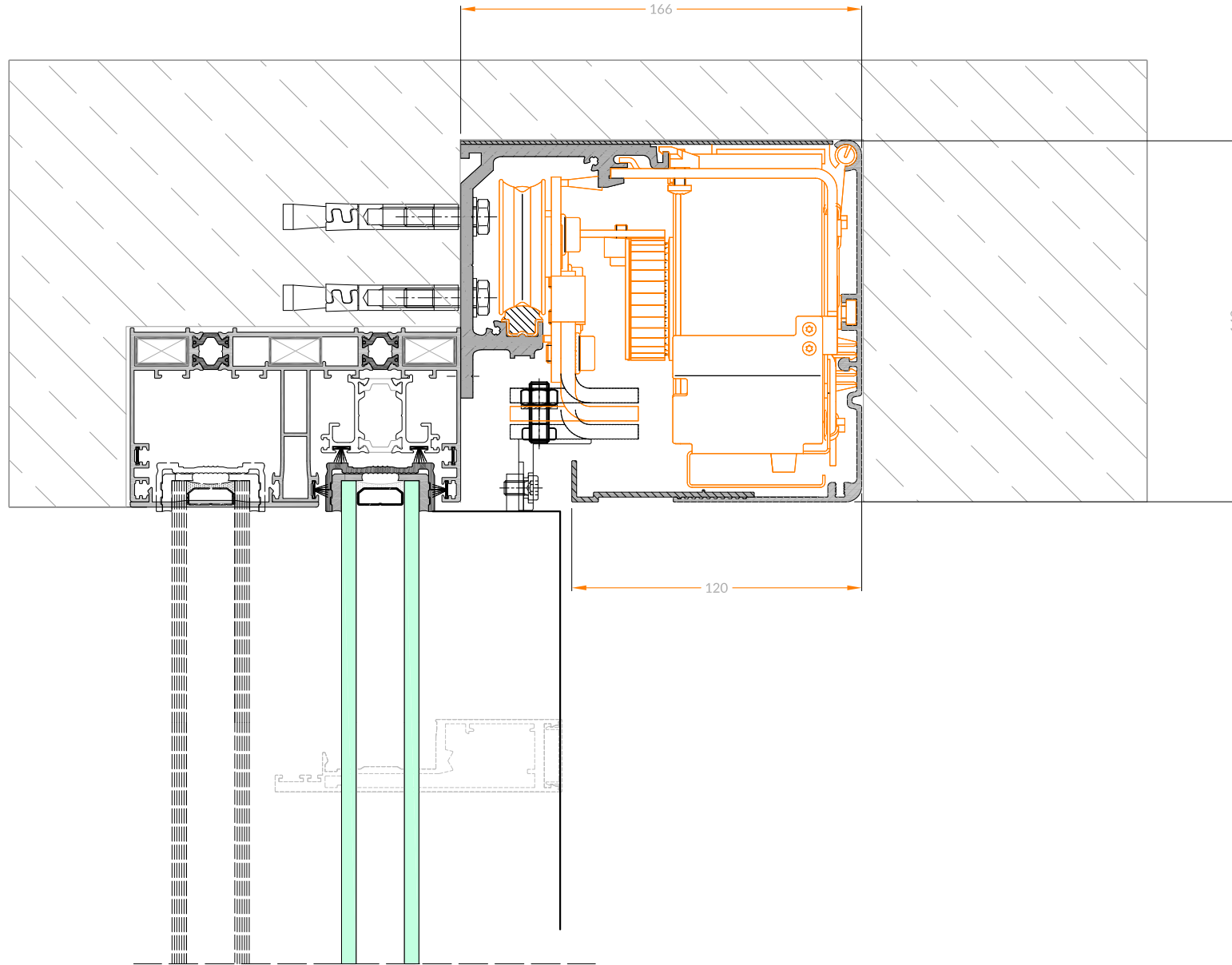

LOCKING DEVICES

8.1

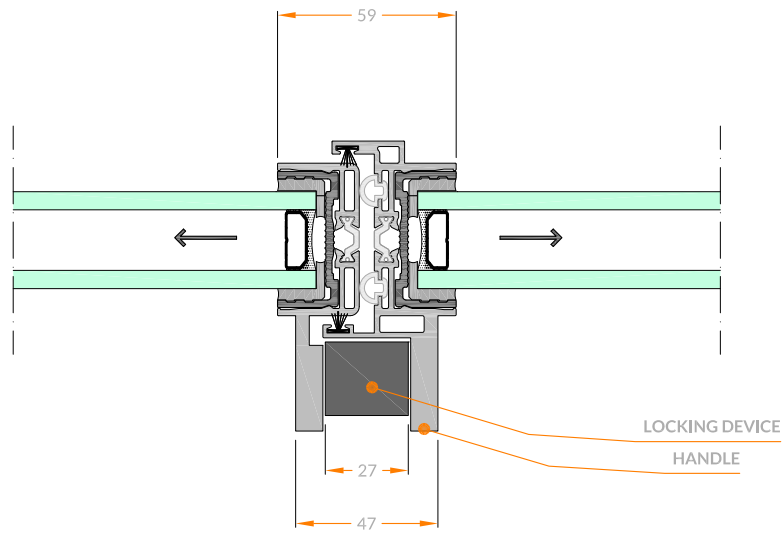

13

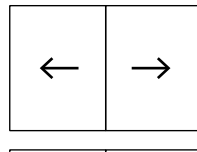

Sliding away from each other (same track)

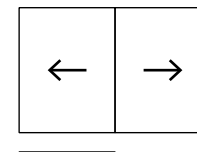
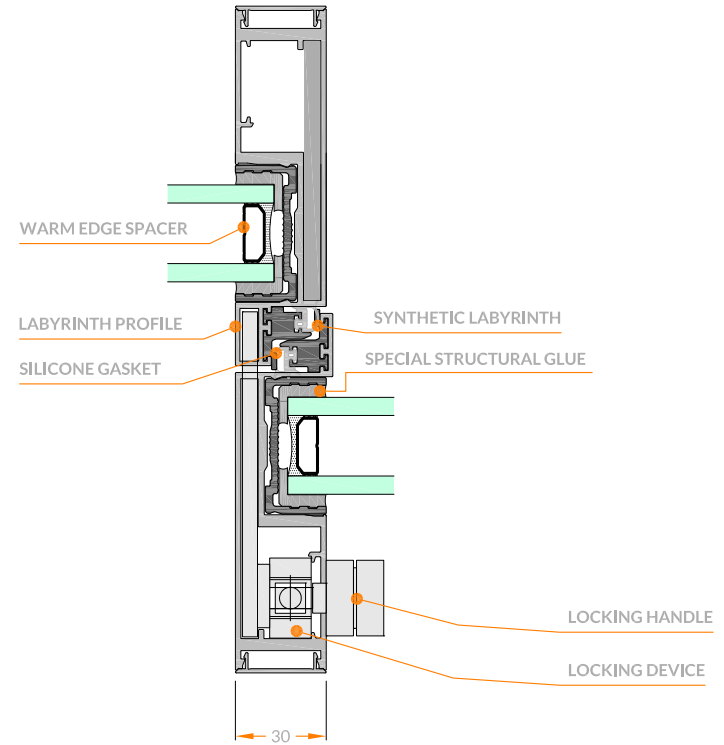

Sliding away from each other (different track)

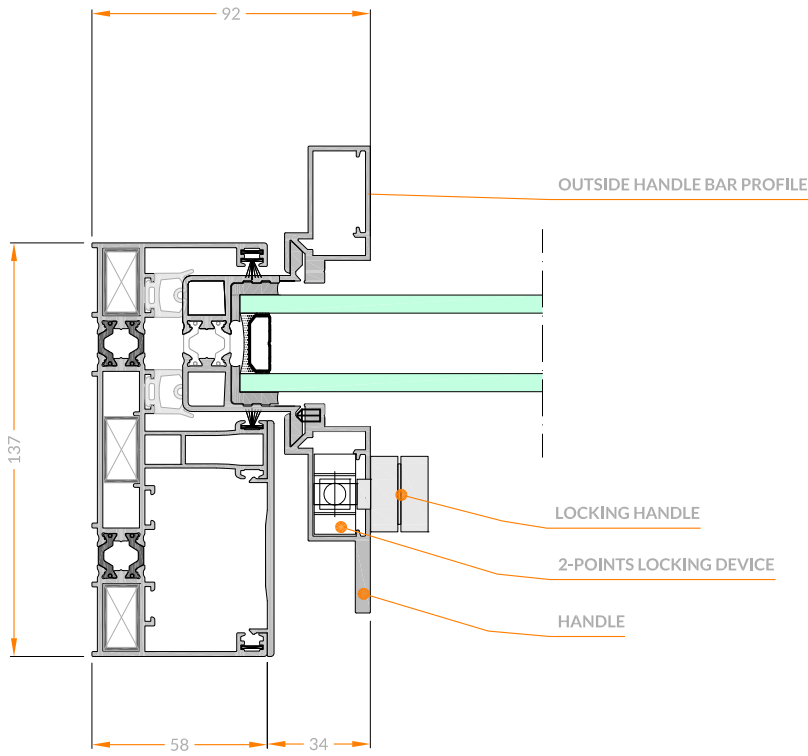

Side handle
Inside & outside

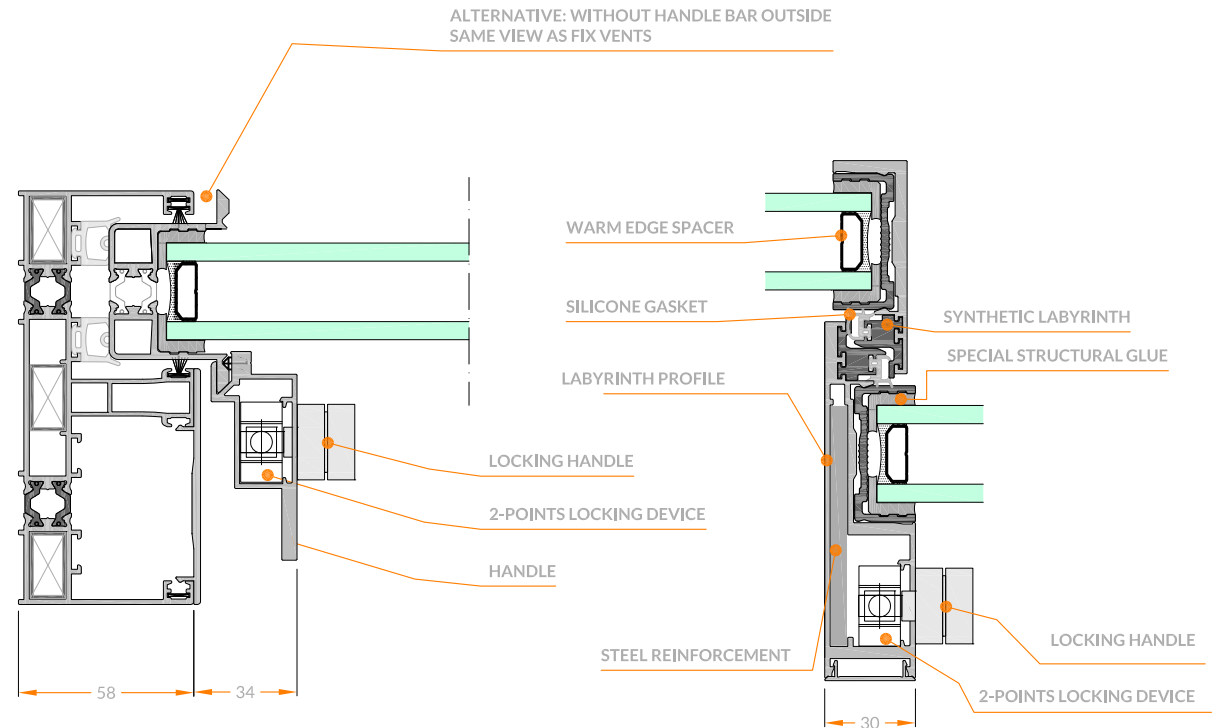

2

11

Side handle
Inside only

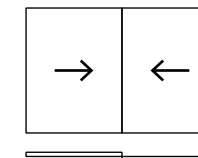

Successive
sliding frames
(different track)

OMICRON • INVISIBLE BASE

9.1

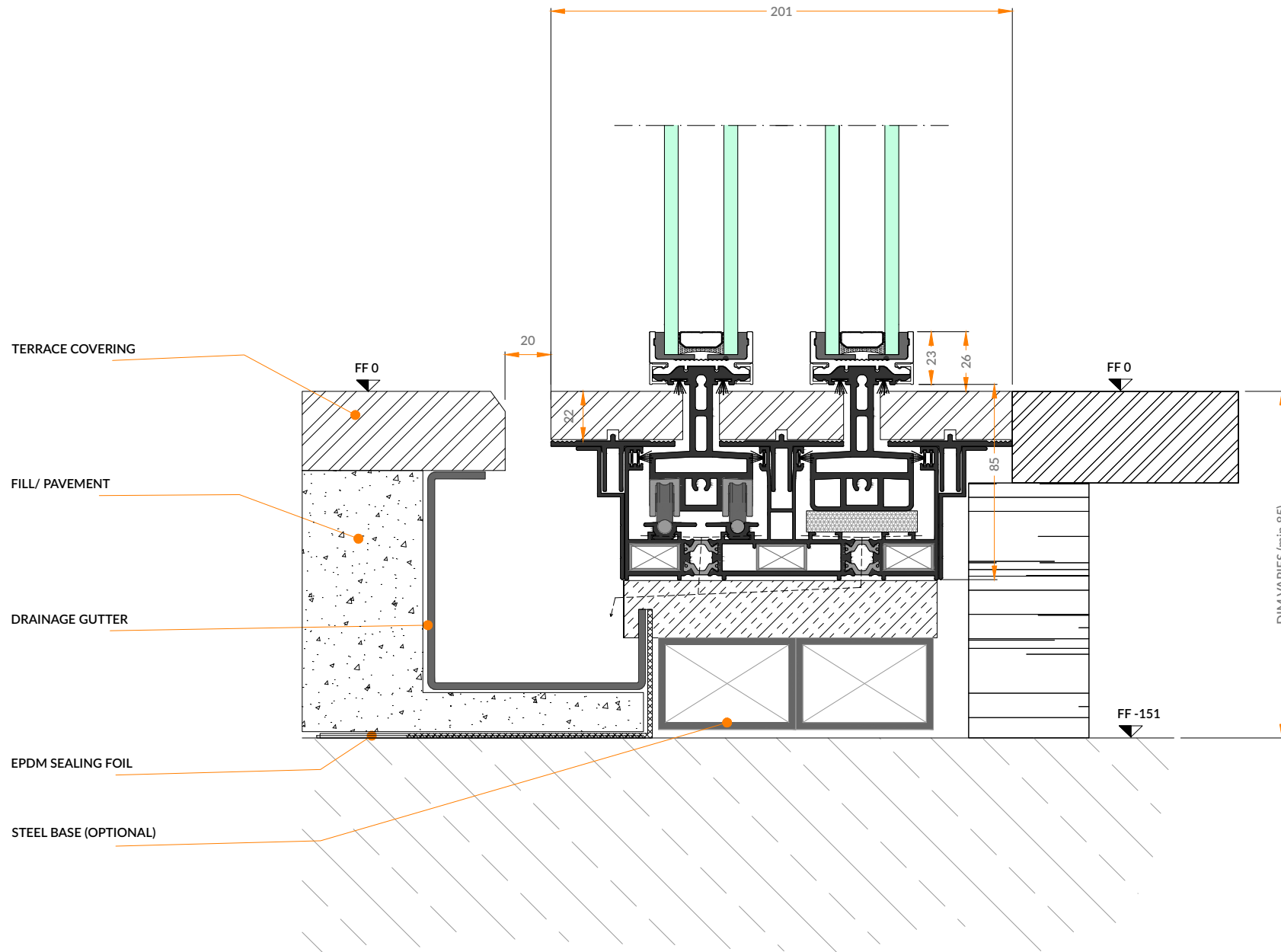

SYNTHETIC BASE WITH SUB-FRAME

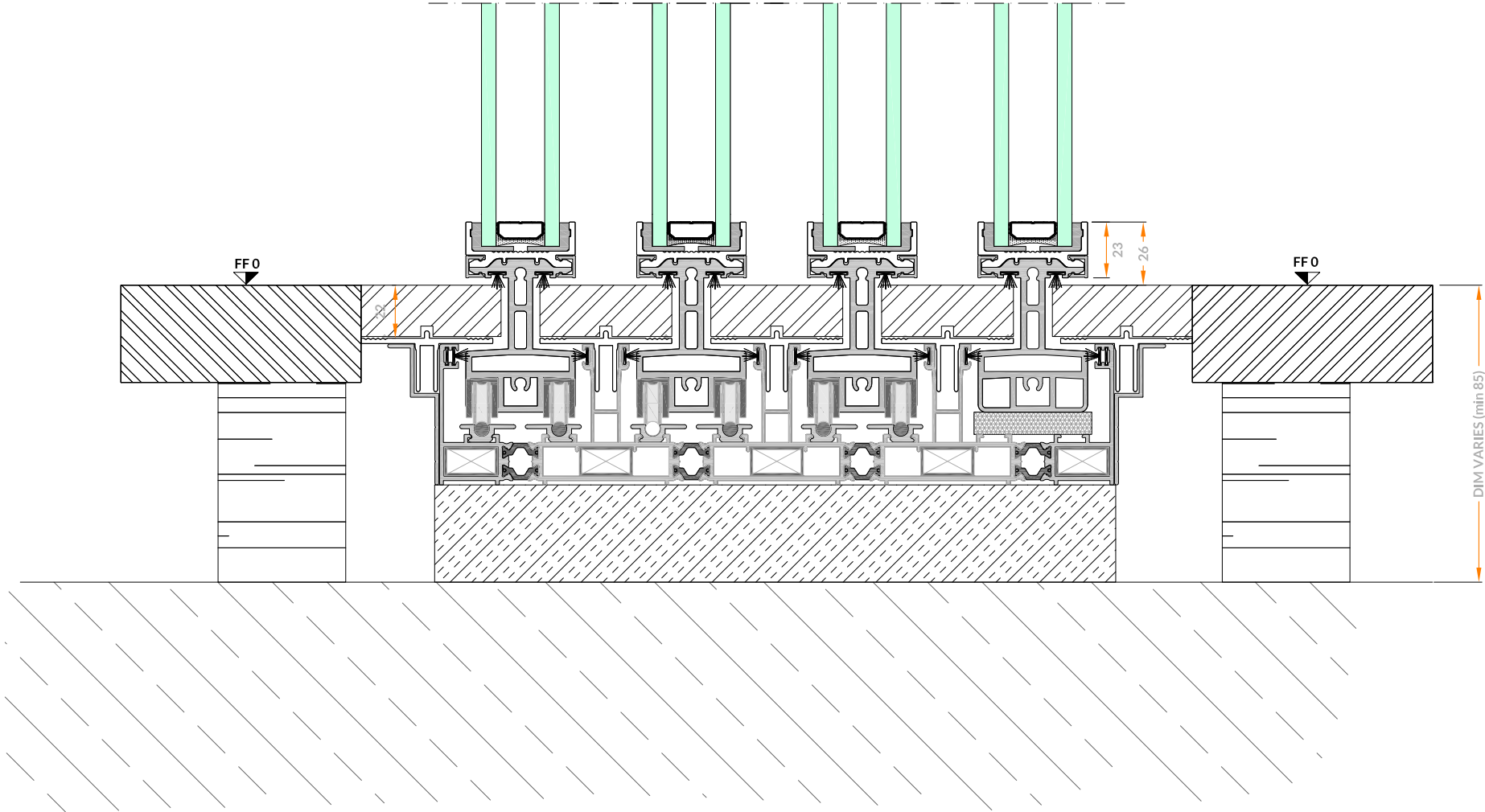

9.2

SYNTHETIC BASE WITH SUB-FRAME

BASE SECTIONS

9.3

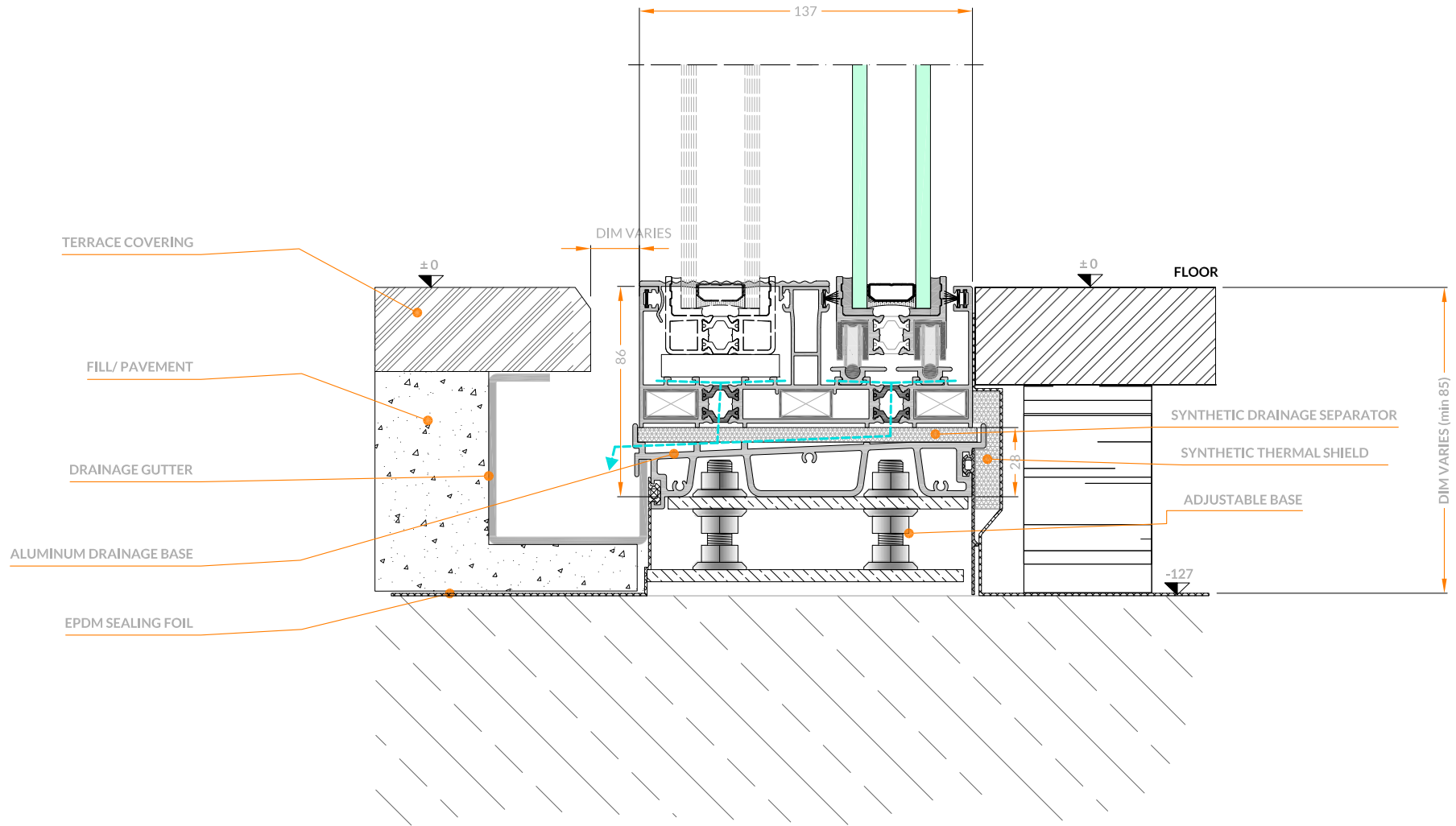

ALUMINUM BASE WITH ADJUSTABLE SUPPORT

BASE SECTIONS

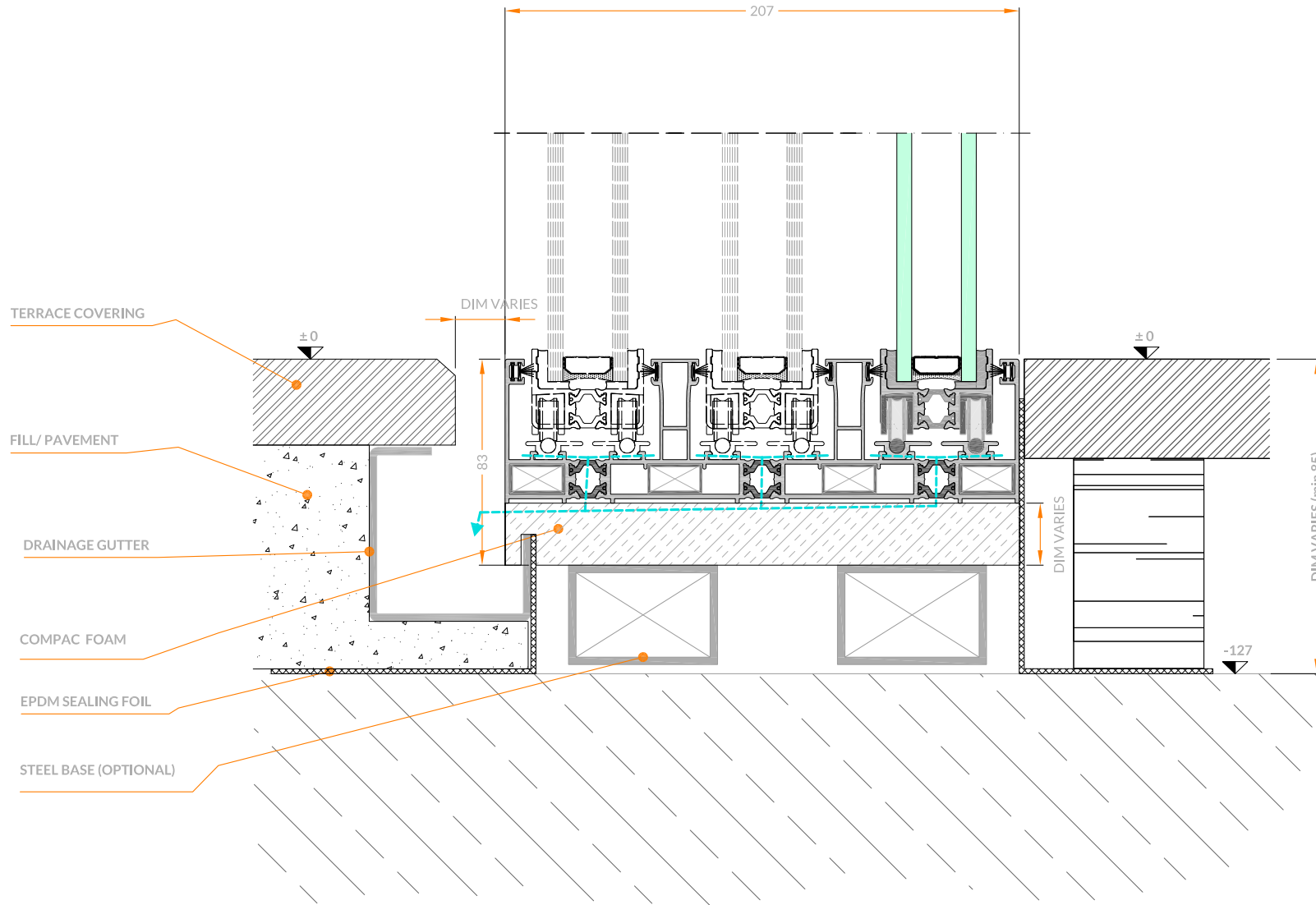

9.4

SYNTHETIC BASE WITH SUB-FRAME

BASE SECTIONS

9.5

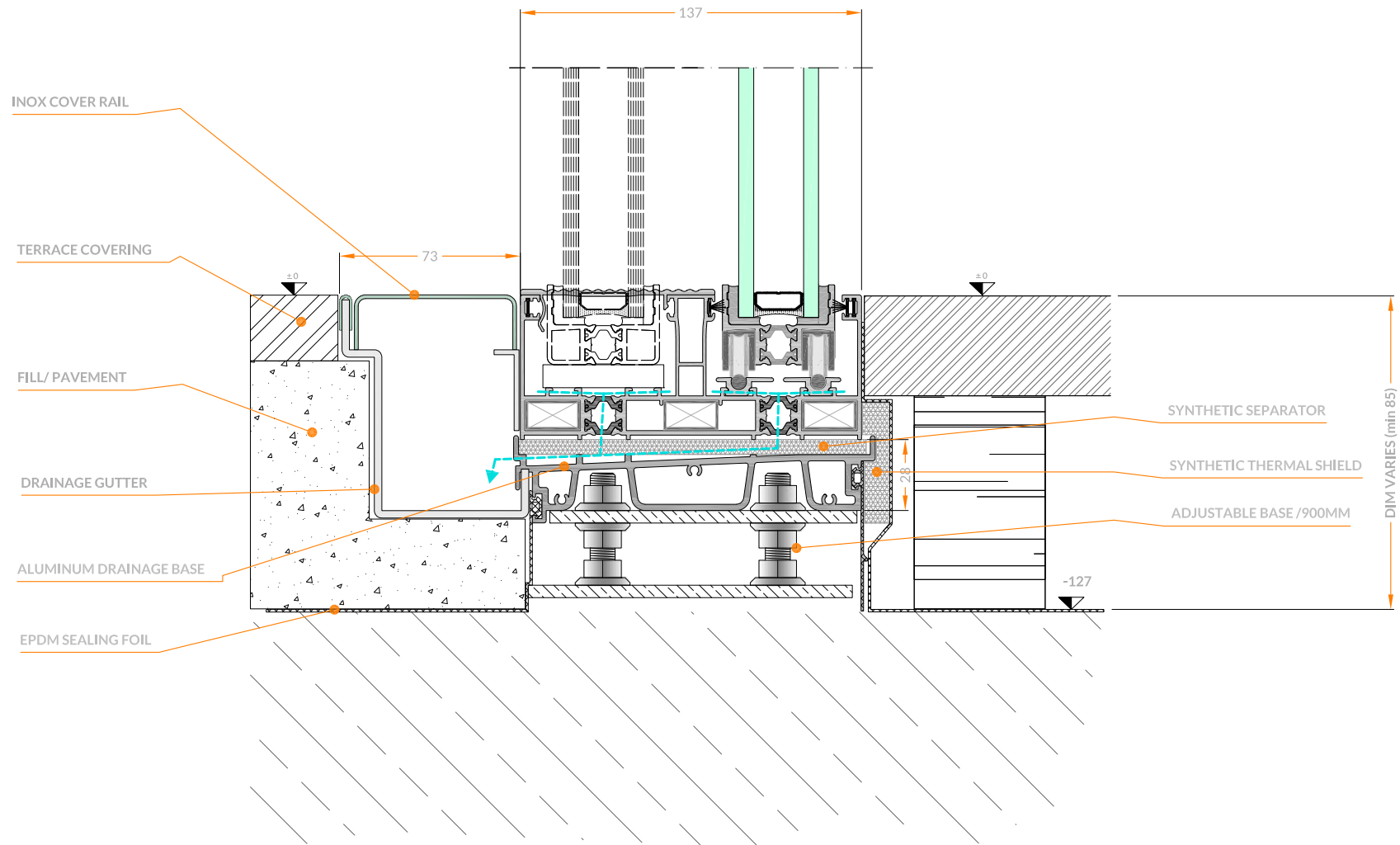

ALUMINUM BASE WITH ADJUSTABLE SUPPORT B

BASE SECTIONS

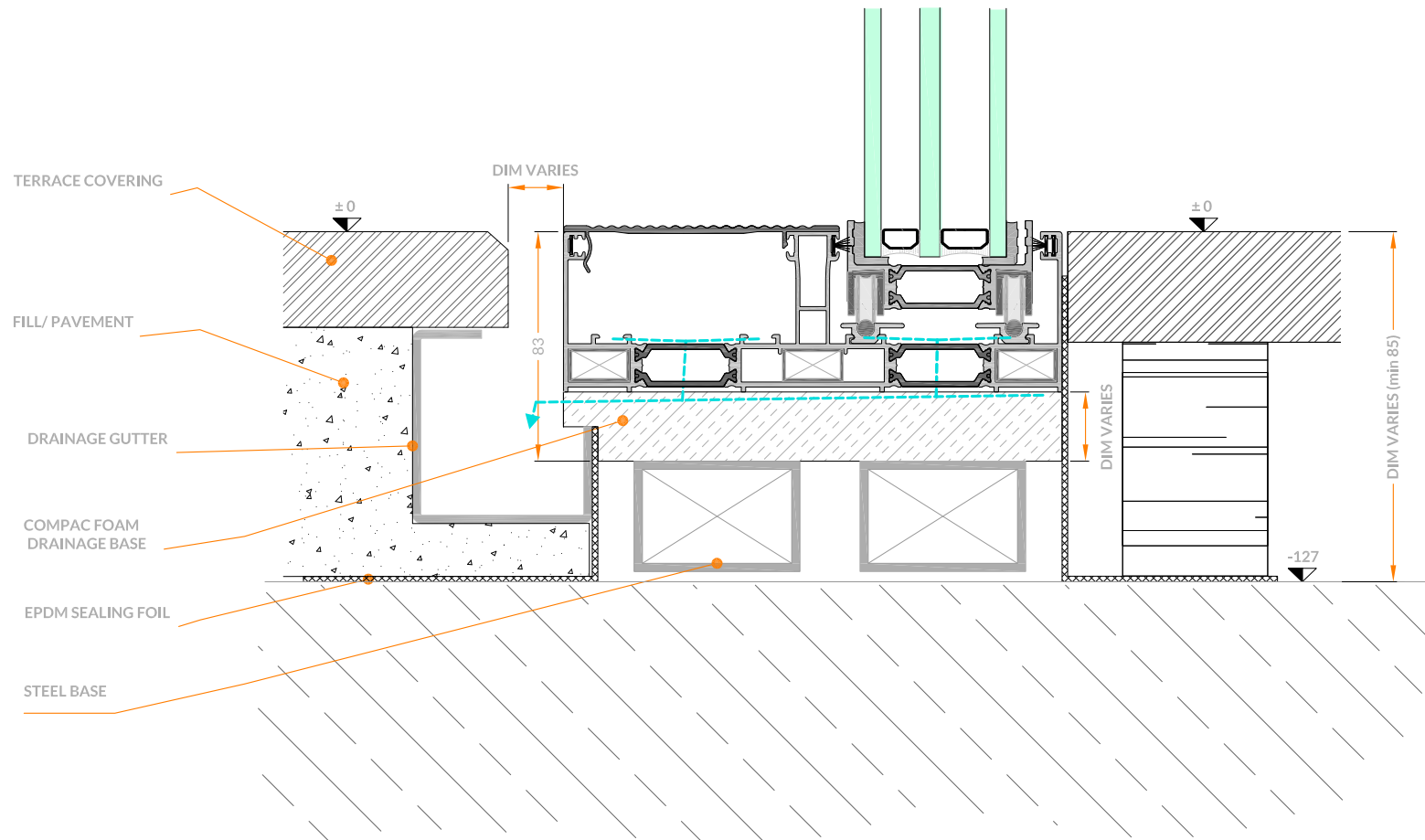

INSTALLATION MODES

10.1

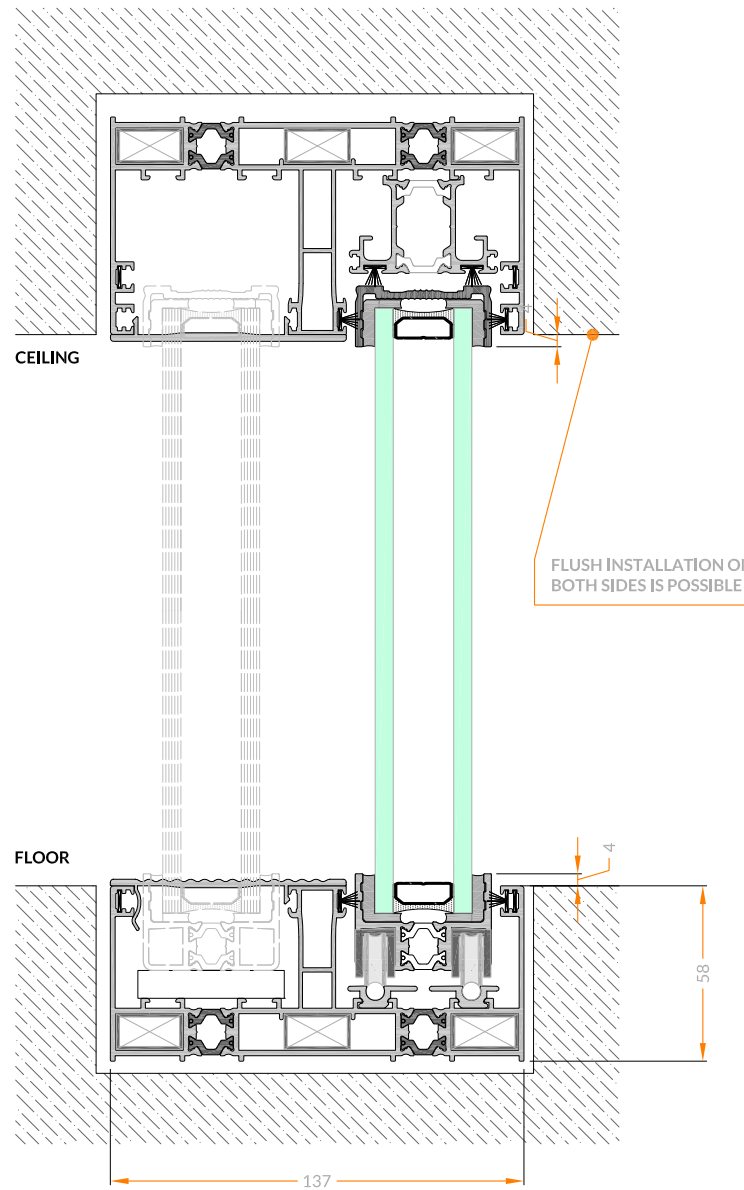

VERTICAL SECTION

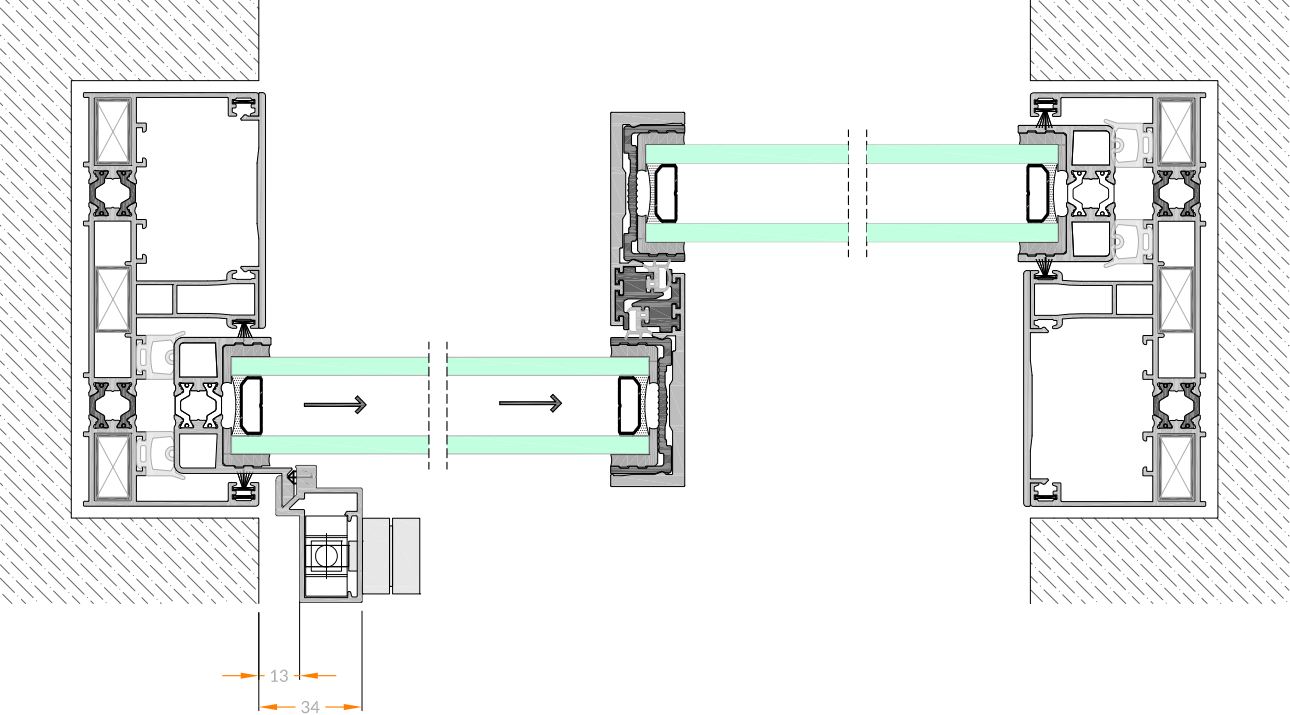

HORIZONTAL SECTION

MAIN FRAME SOLUTIONS



SINGLE FIX
11.1



DOUBLE FIX
11.2

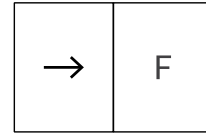

SLIDING FIX
11.3

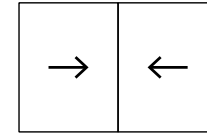

DOUBLE SLIDING
11.4

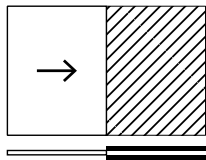

POCKET · SINGLE TRACK
11.5

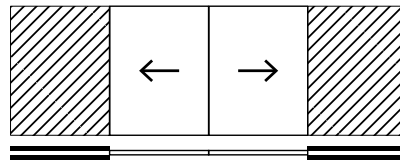

POCKET · SINGLE TRACK
11.5

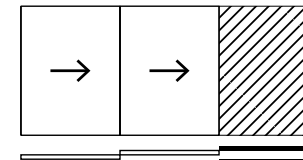

POCKET · DOUBLE TRACK
111.6

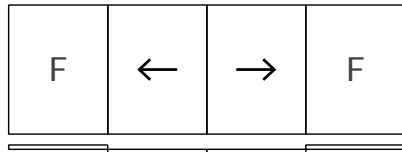

FIX · DOUBLE SLIDING · FIX
11.7

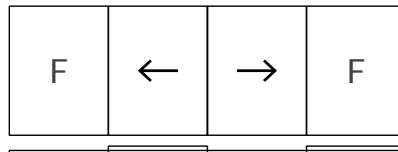

FIX · DOUBLE SLIDING · FIX
11.8

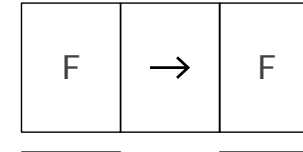

FIX · SLIDING · FIX
11.9

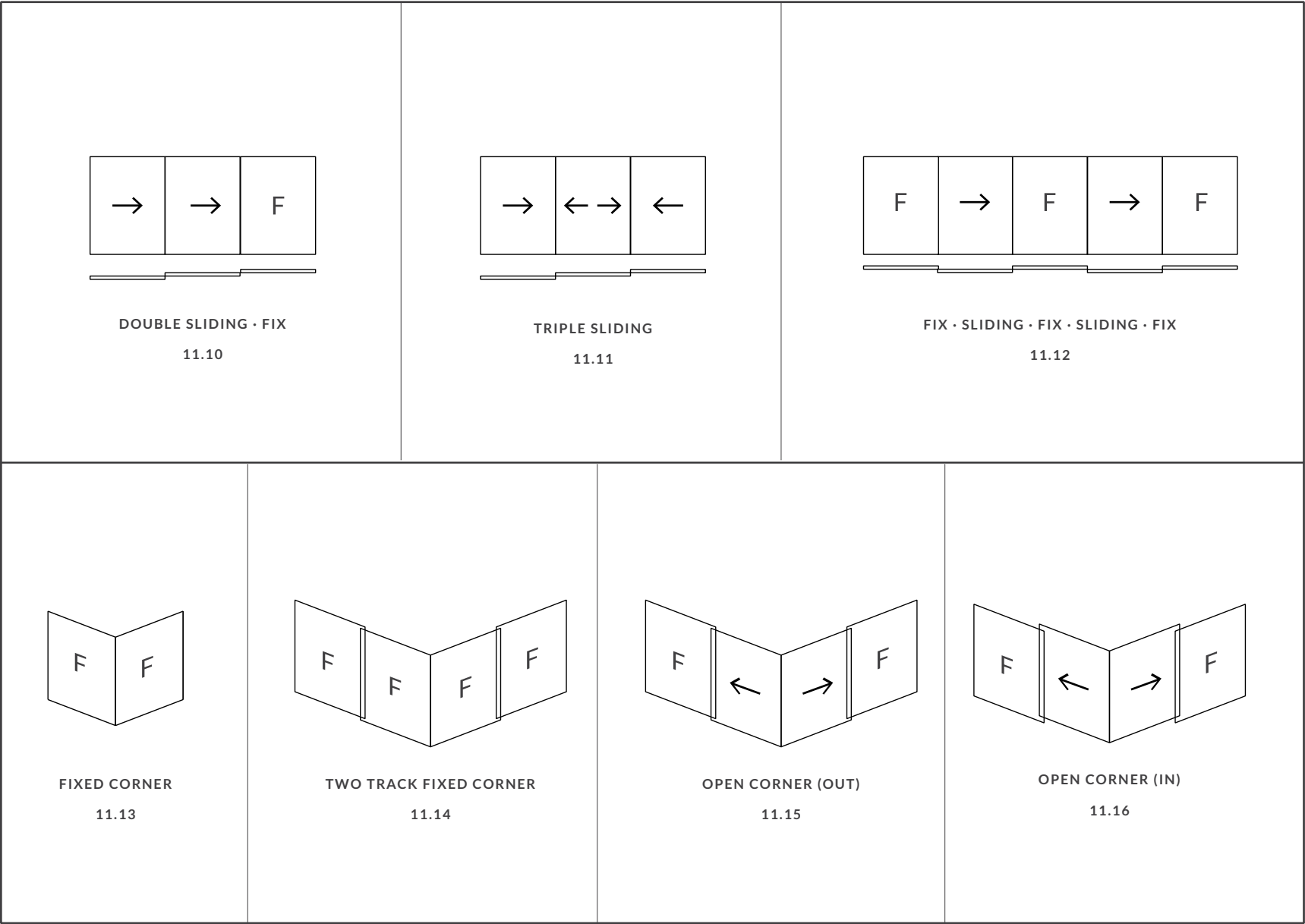

FIX FRAME

11.1

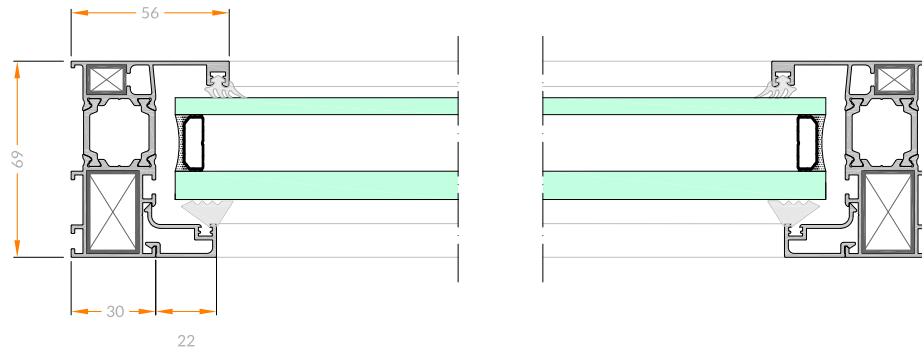

HORIZONTAL SECTION

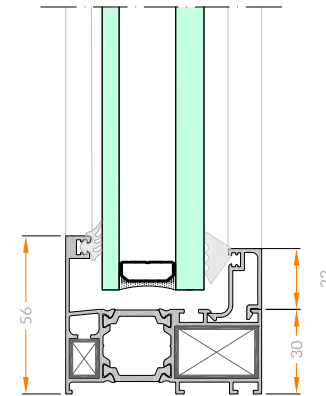
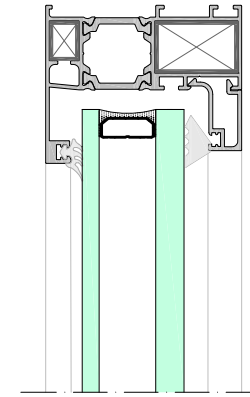

VERTICAL SECTION



DOUBLE FIX FRAME

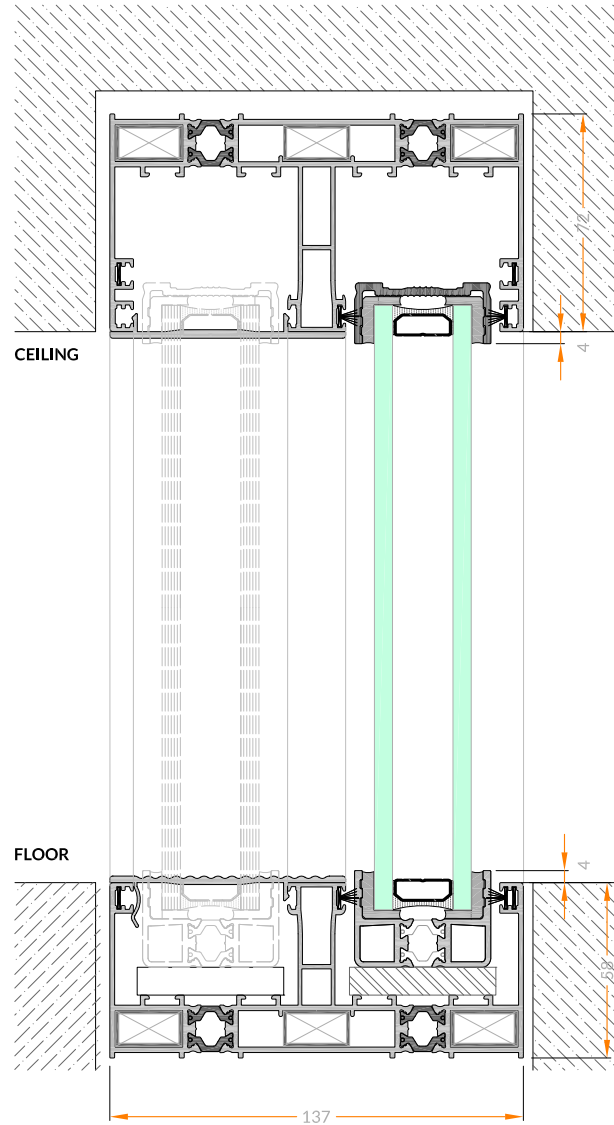

VERTICAL SECTION

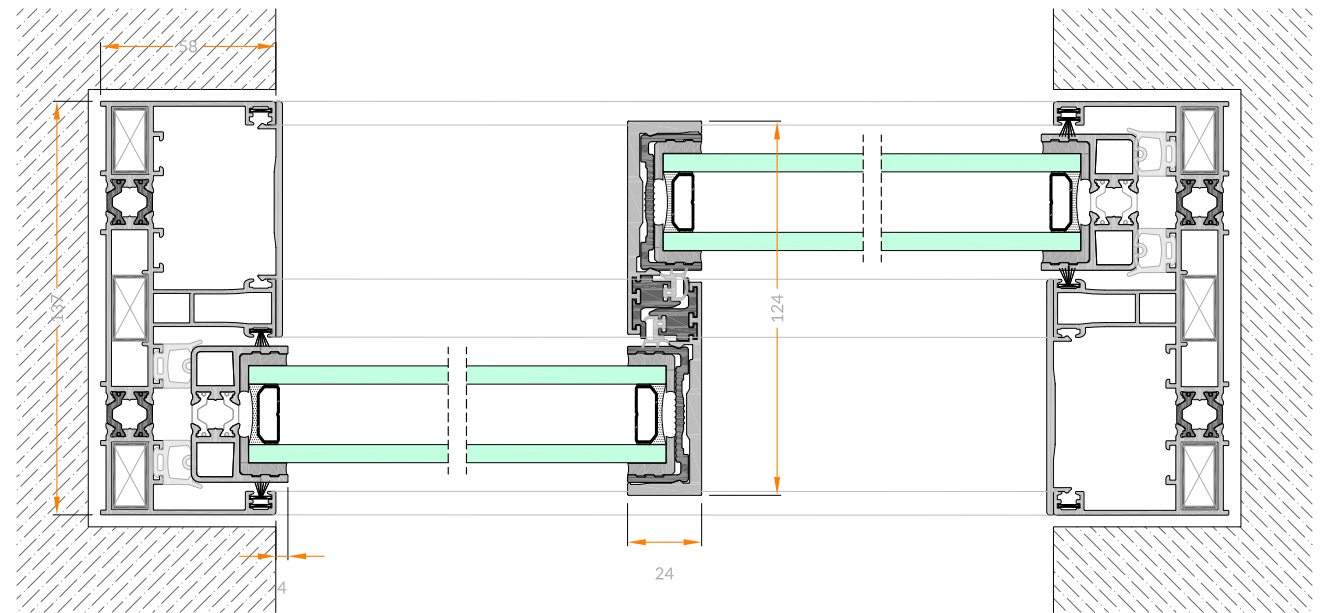

HORIZONTAL SECTION

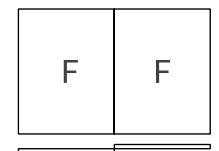

DOUBLE SLIDING FRAME

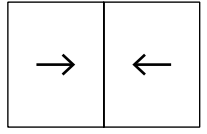
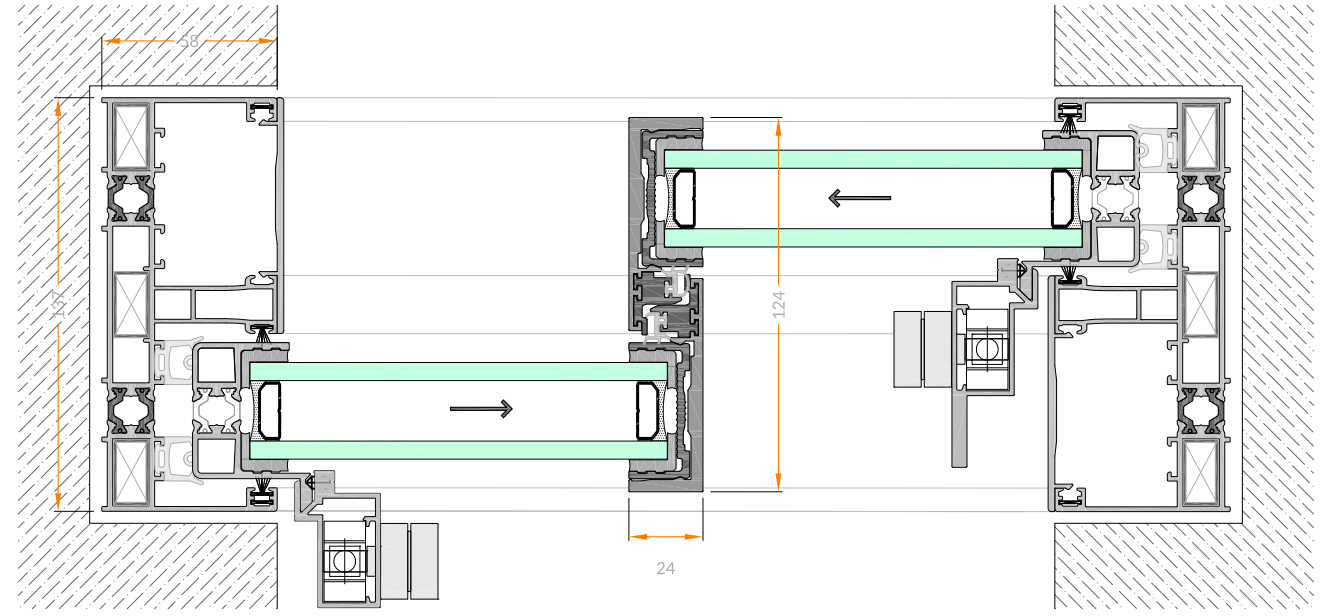
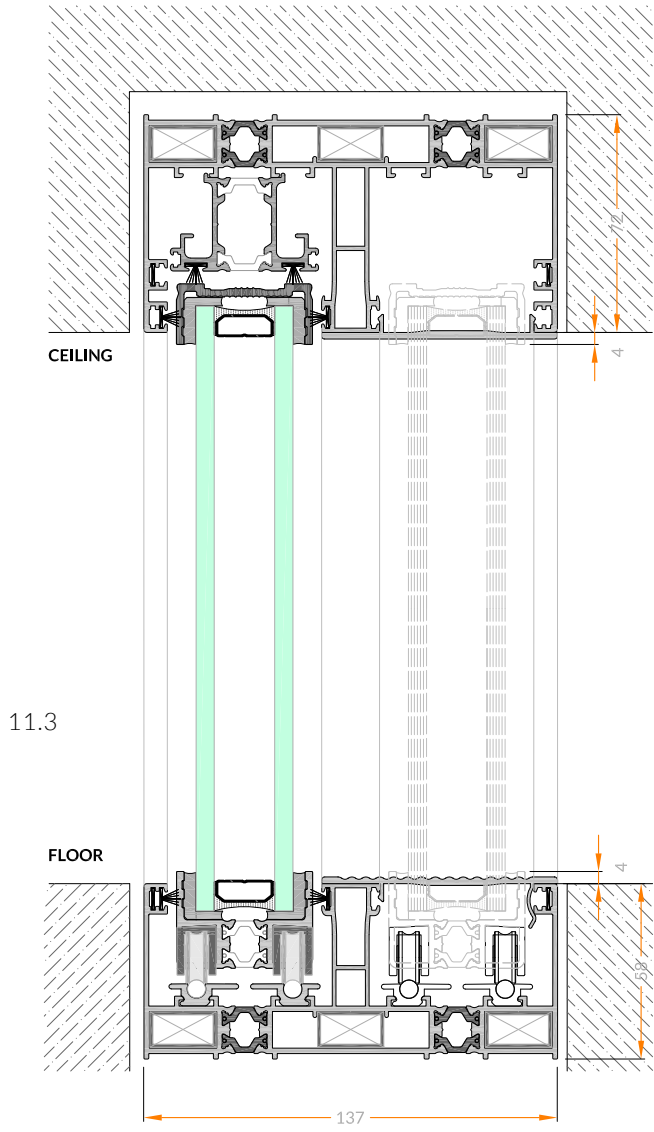

VERTICAL SECTION

HORIZONTAL SECTION

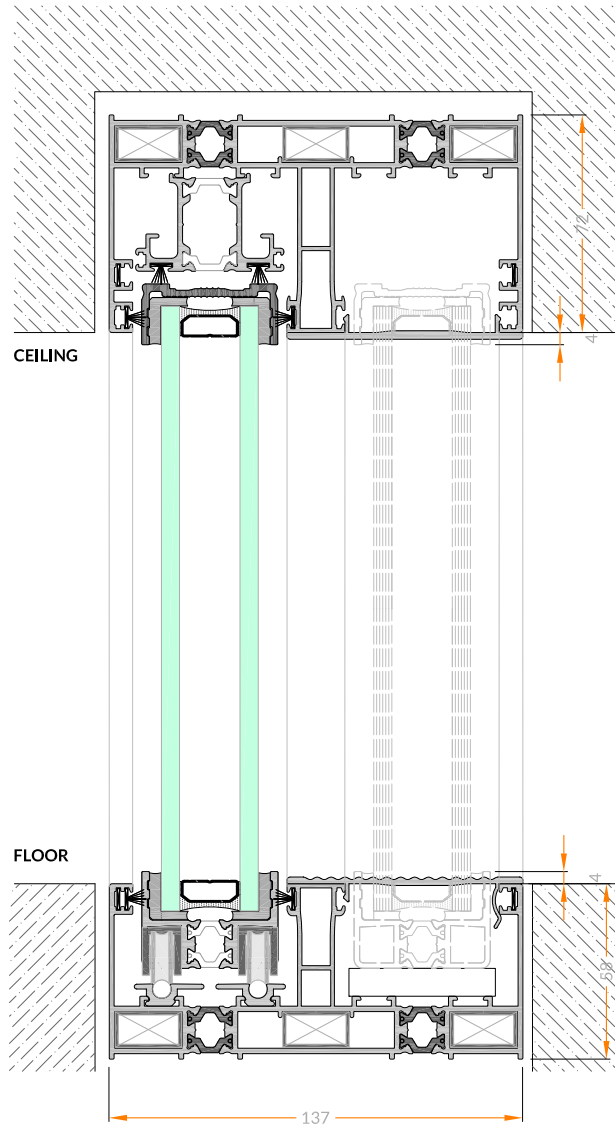

VERTICAL SECTION

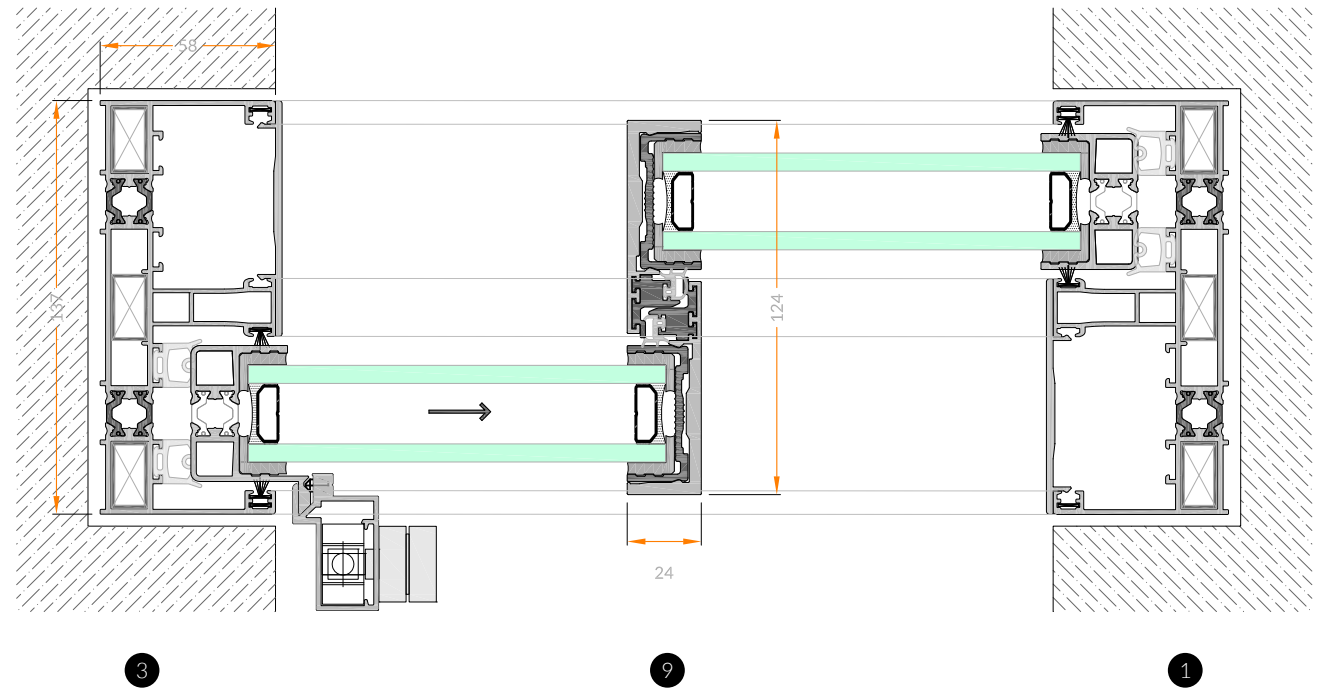

HORIZONTAL SECTION

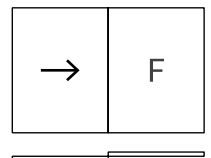

POCKET WINDOWS · SINGLE TRACK

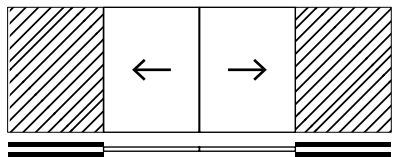
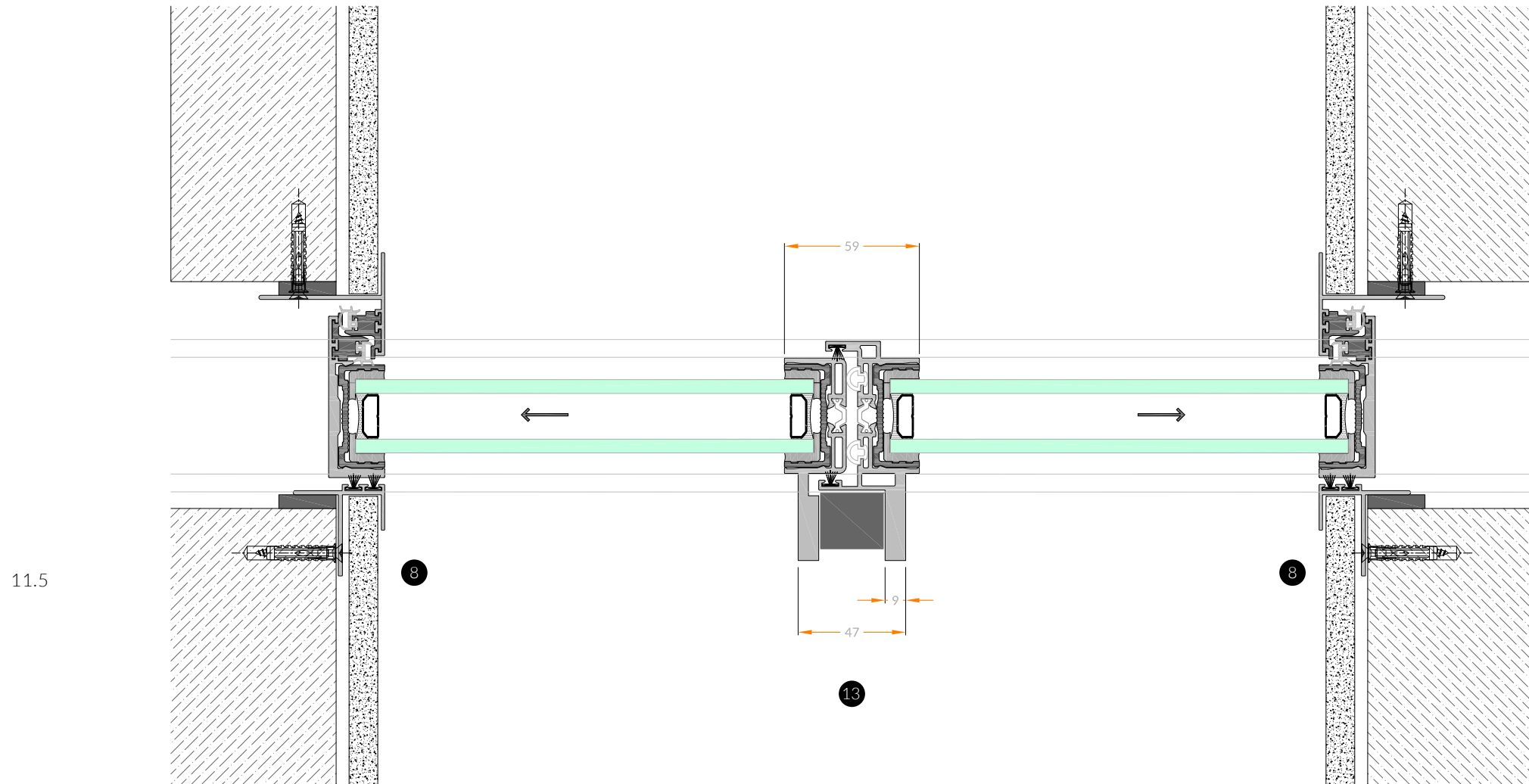

HORIZONTAL SECTION · CLOSED

POCKET WINDOWS · SINGLE TRACK

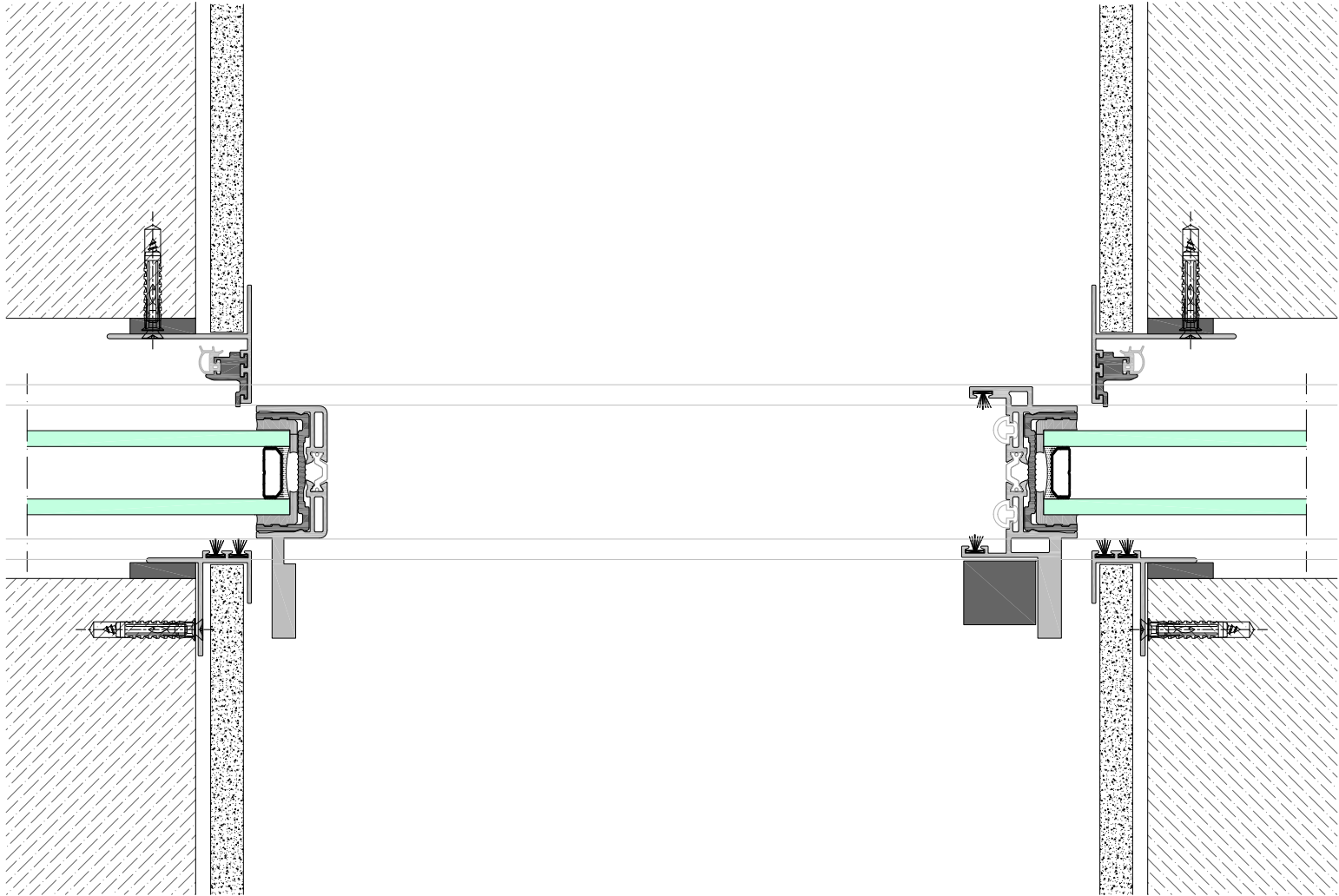

11.5

HORIZONTAL SECTION · OPEN

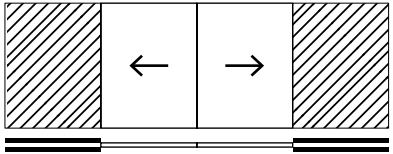

POCKET WINDOWS · DOUBLE TRACK

11.6

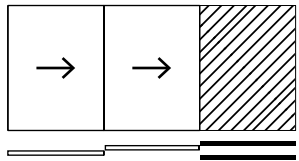
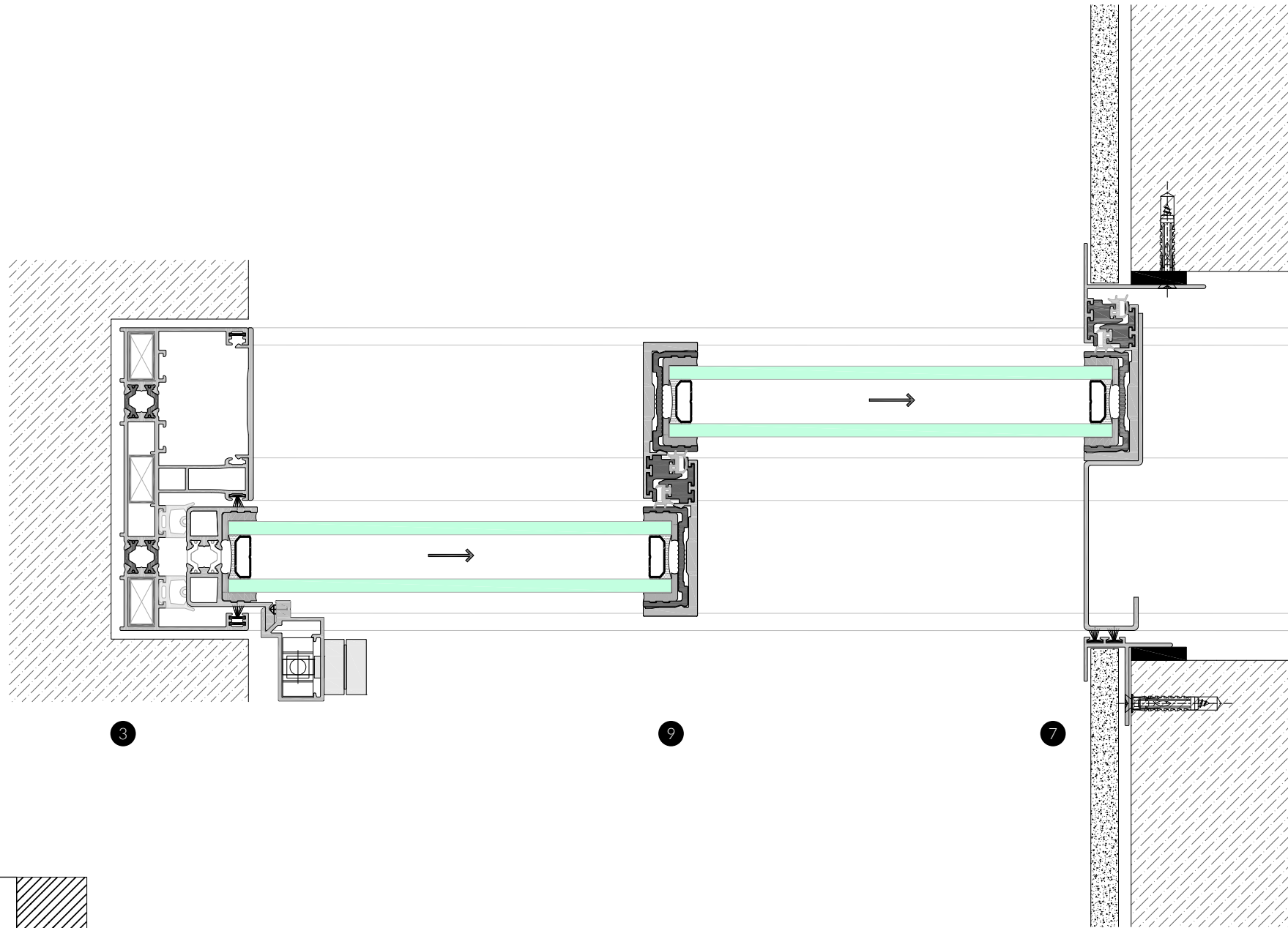

HORIZONTAL SECTION · OPEN

POCKET WINDOWS · DOUBLE TRACK

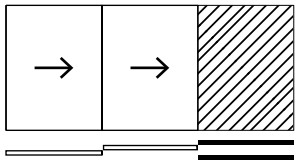
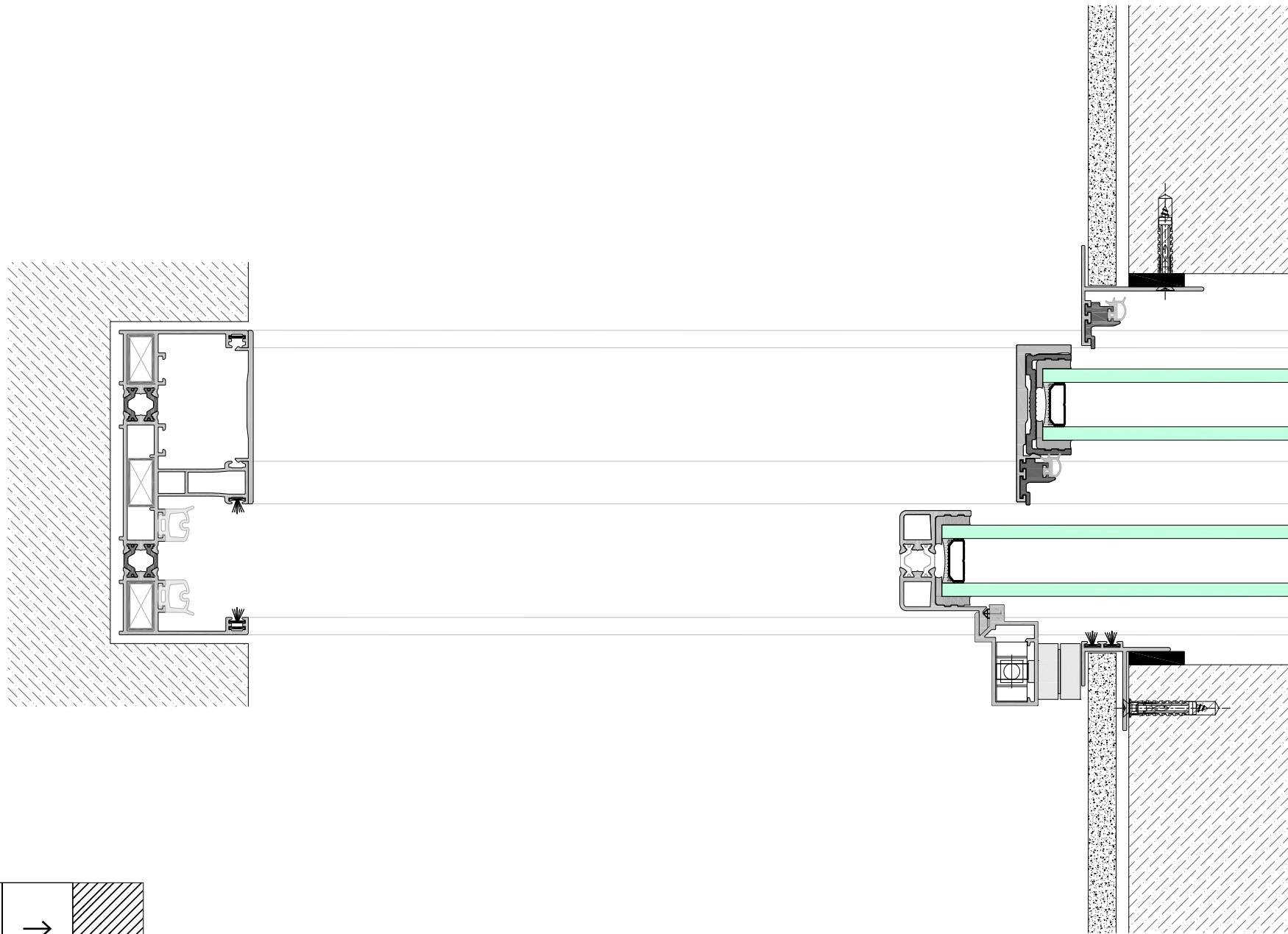

HORIZONTAL SECTION · CLOSED

FIX · DOUBLE SLIDING · FIX (ALTERNATE)

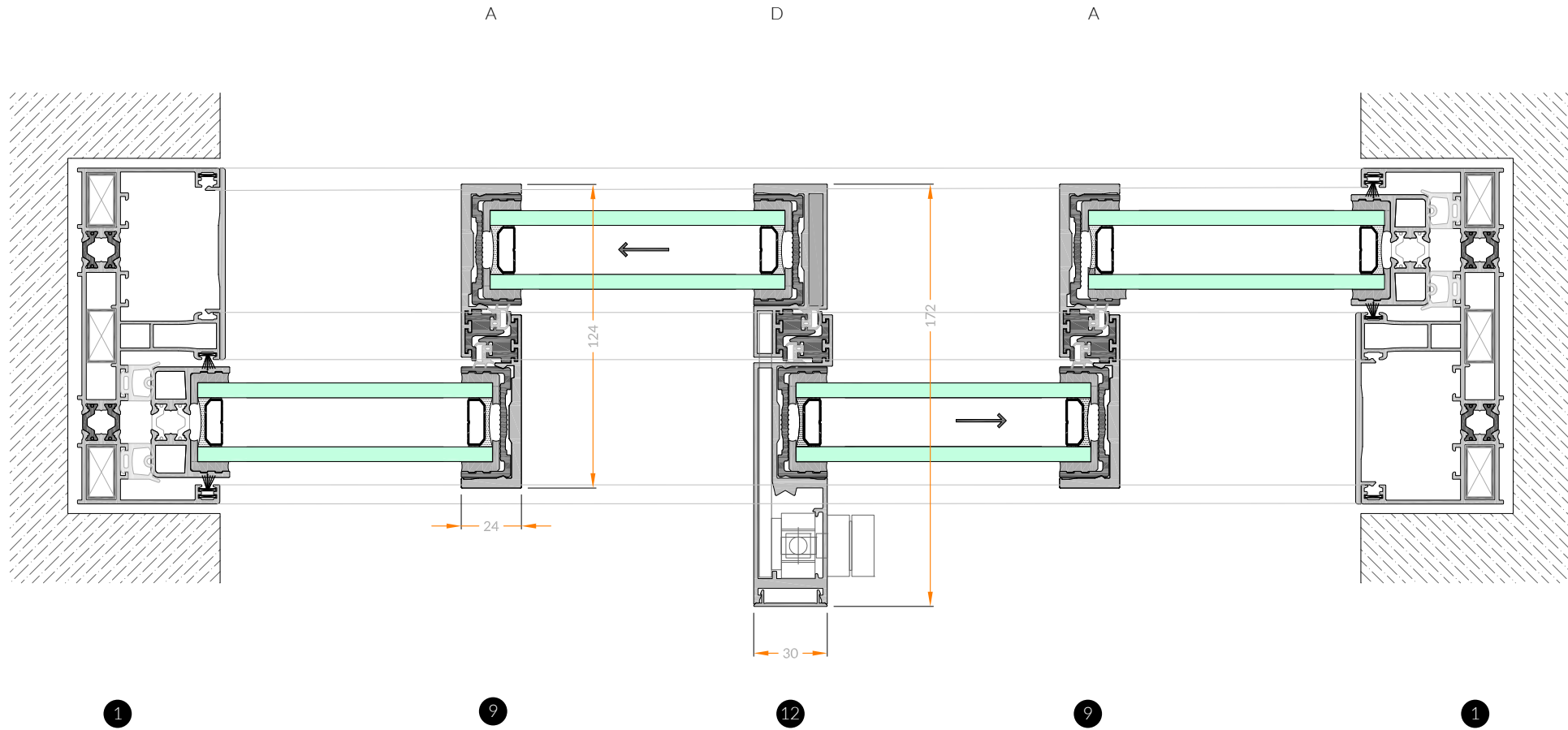

11.7

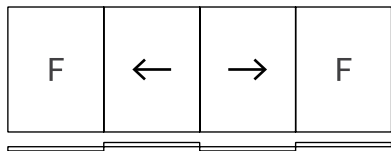

4-POINT LOCKING DEVICE UNDER DEVELOPMENT

FIX · DOUBLE SLIDING IN THE SAME TRUCK · FIX

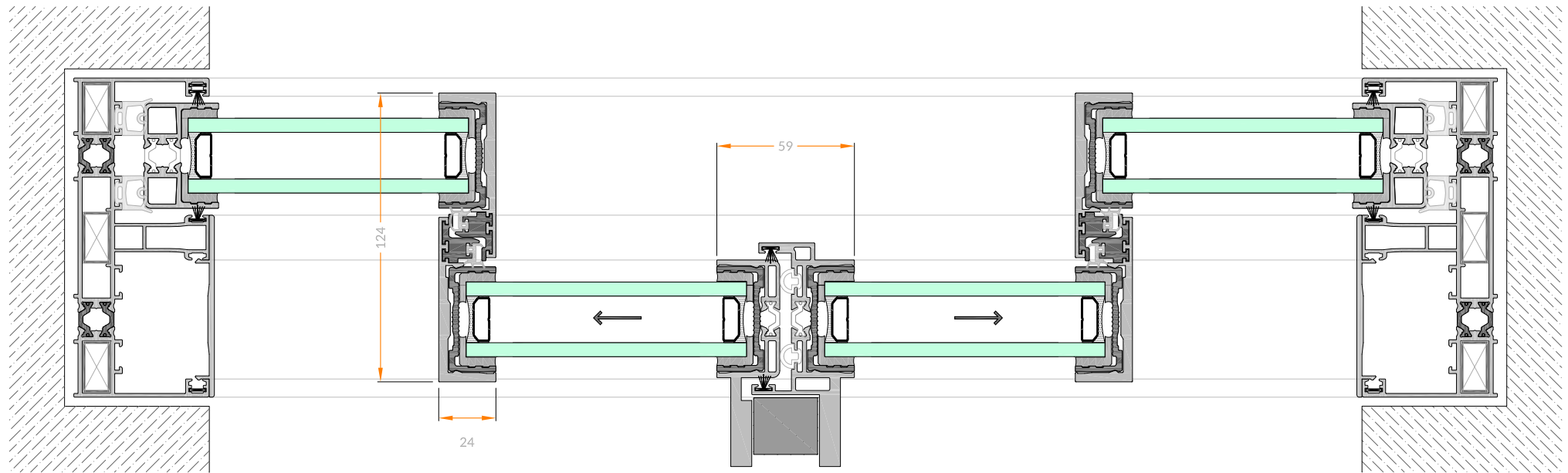

1

9

13

9

1

11.8

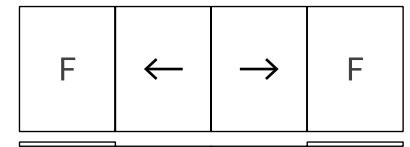

HORIZONTAL SECTION

FIX · SLIDING · FIX

11.9

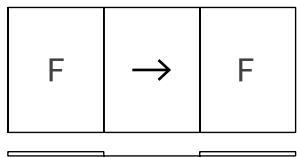
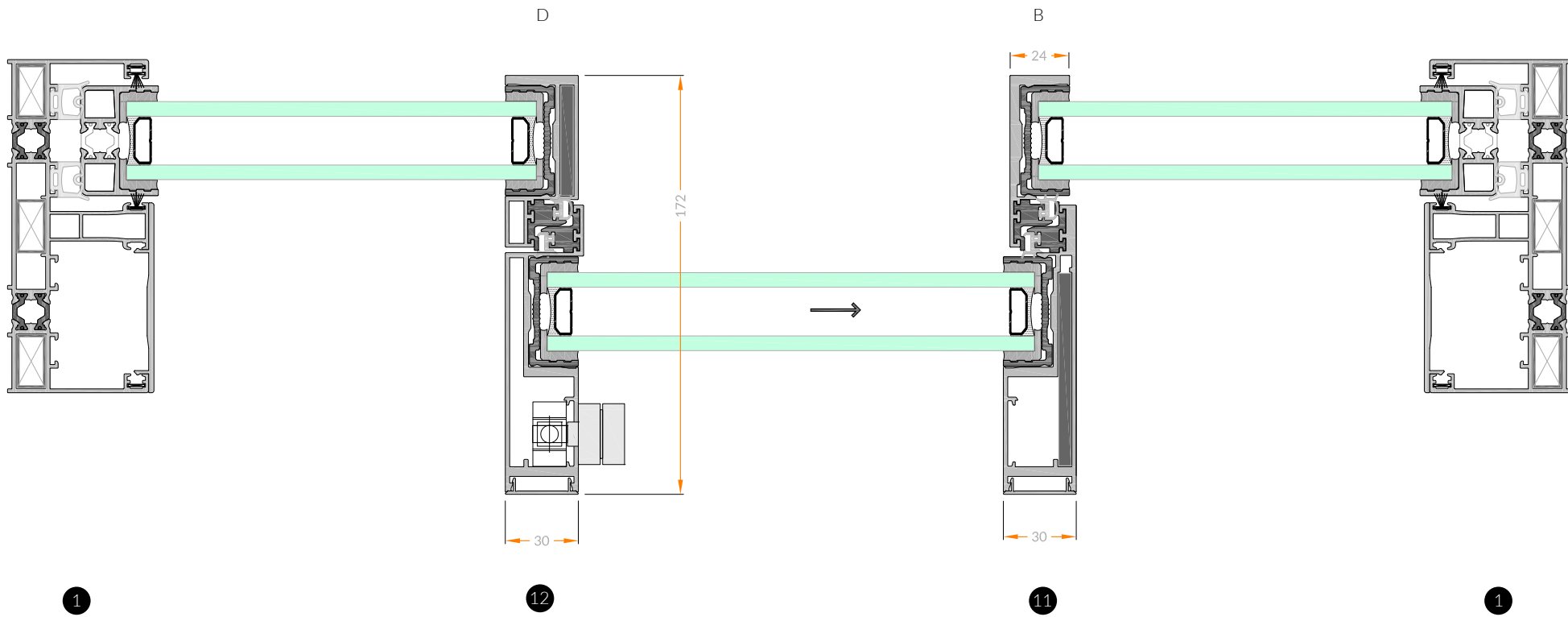

HORIZONTAL SECTION

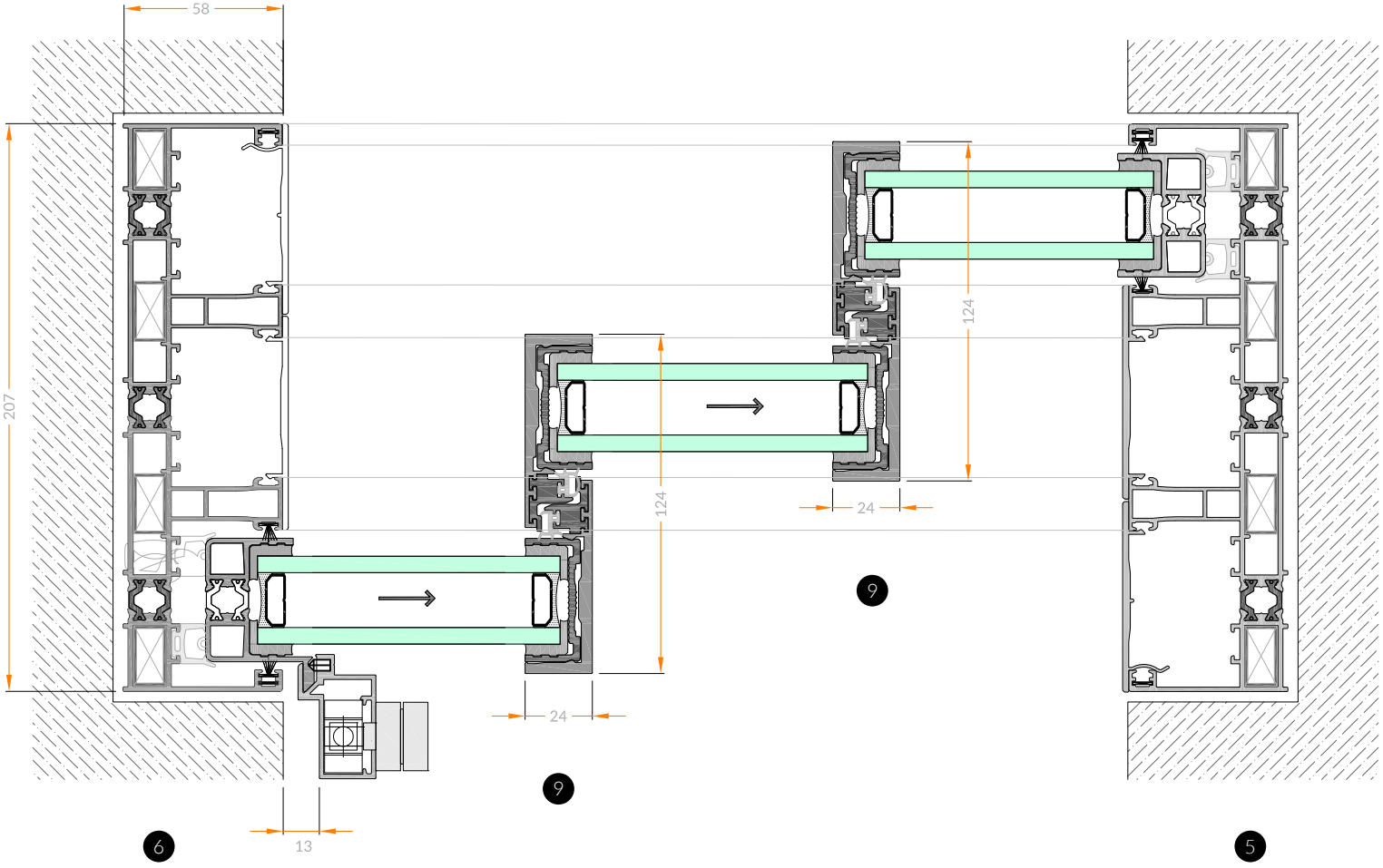

11.10

HORIZONTAL SECTION

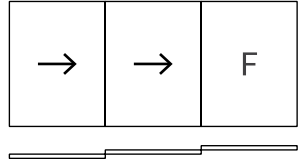

TRIPLE SLIDING

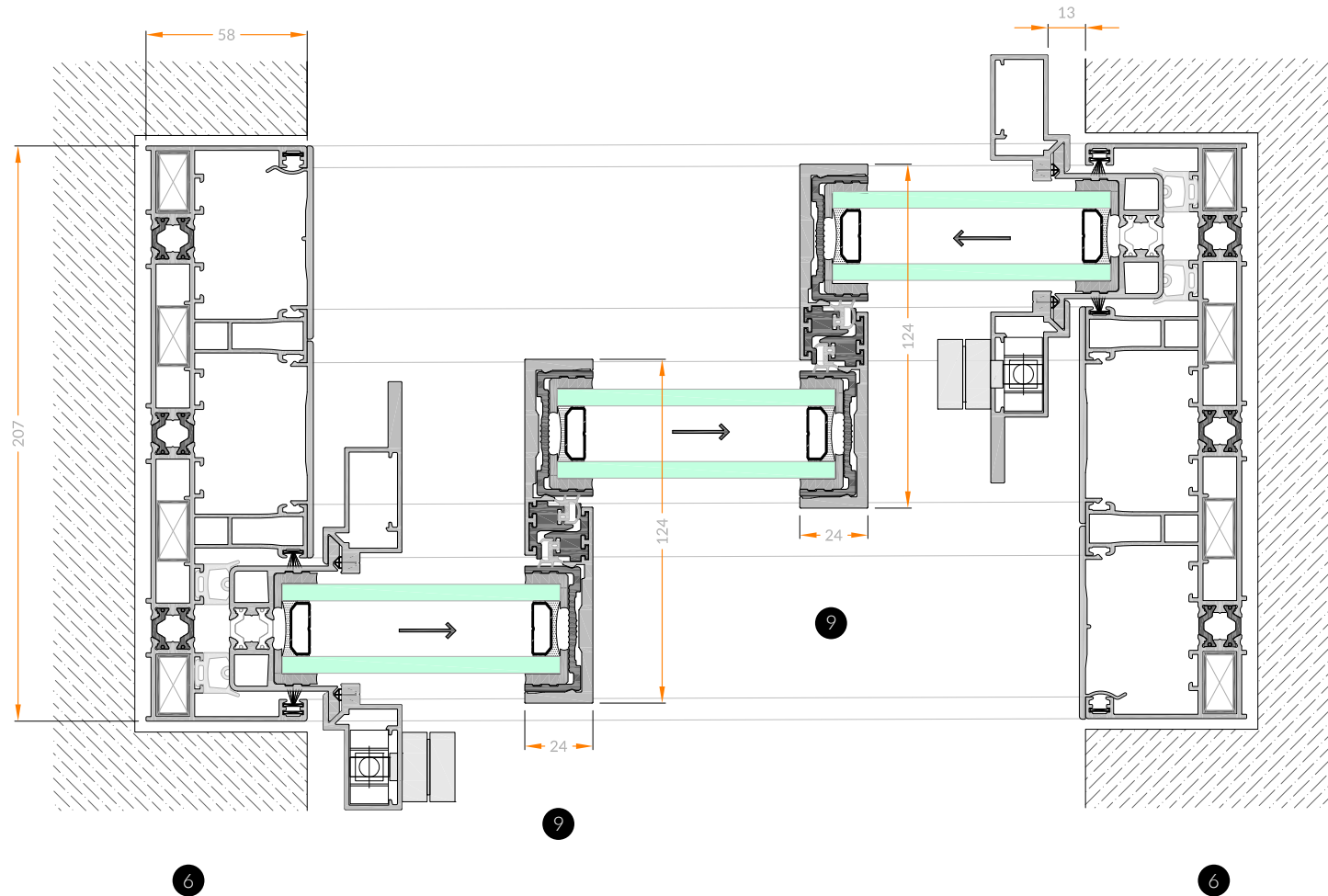

11.11

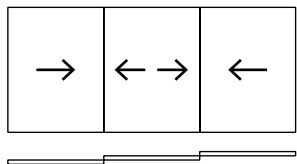

HORIZONTAL SECTION

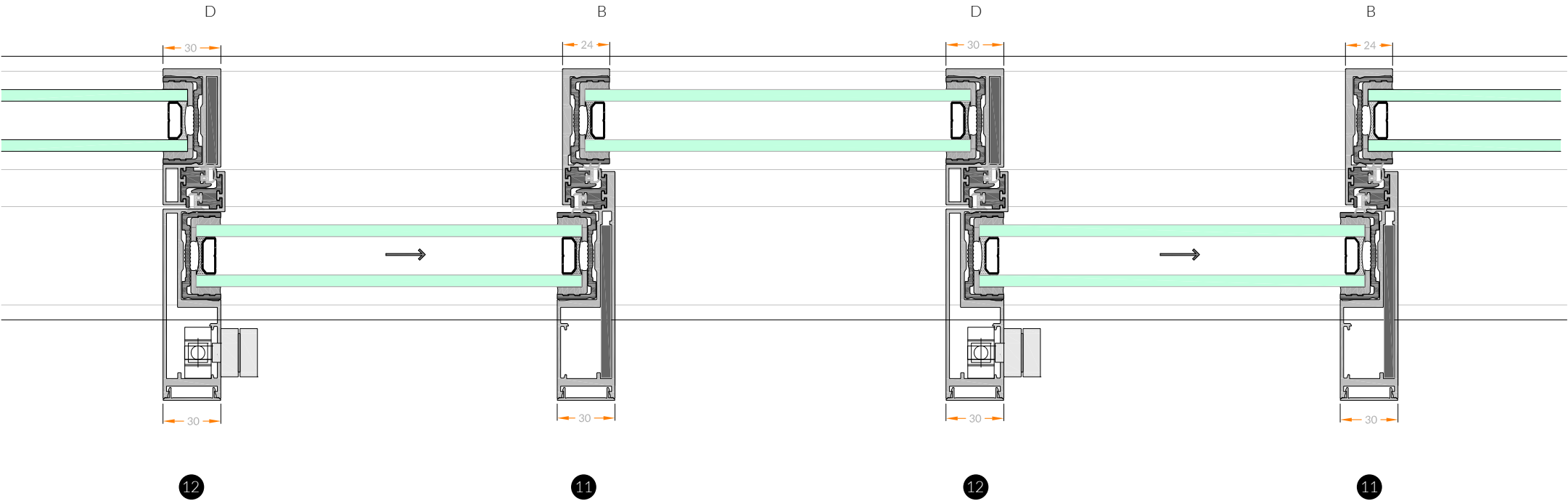

HORIZONTAL SECTION



SINGLE CORNER FRAME

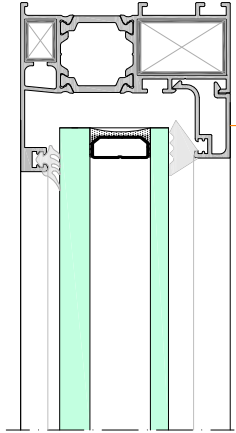
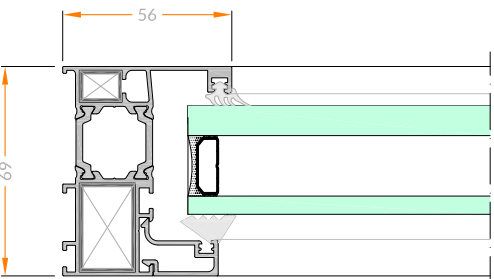
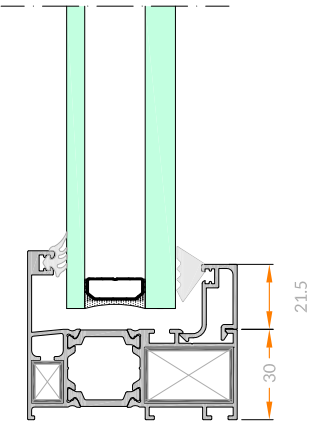
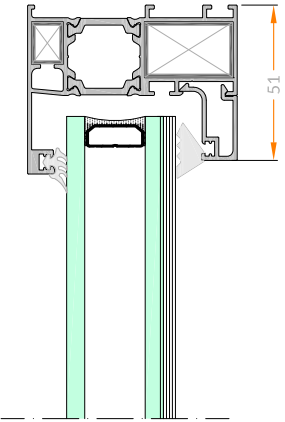

GLAZING BEADS TO THE OUTER SIDE

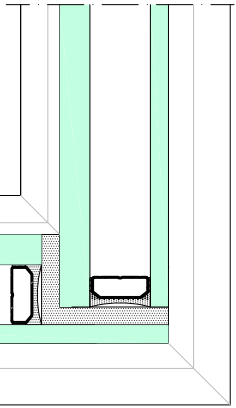

11.13

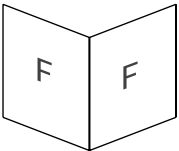

VERTICAL SECTION

HORIZONTAL SECTION

TWO TRACK CLOSED CORNER FRAMES

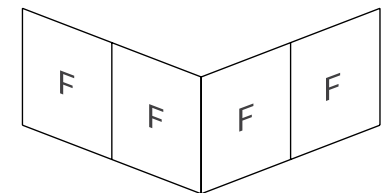
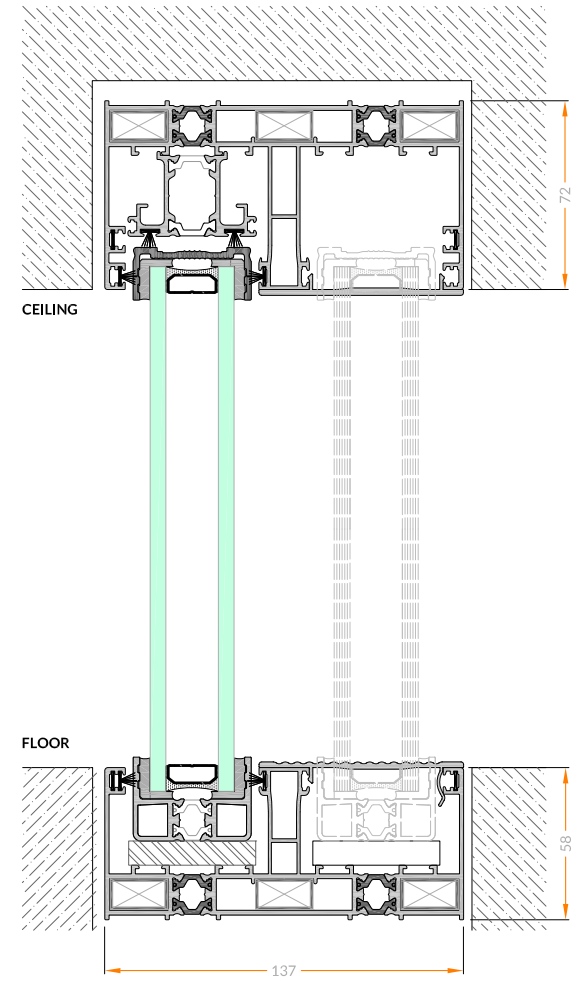
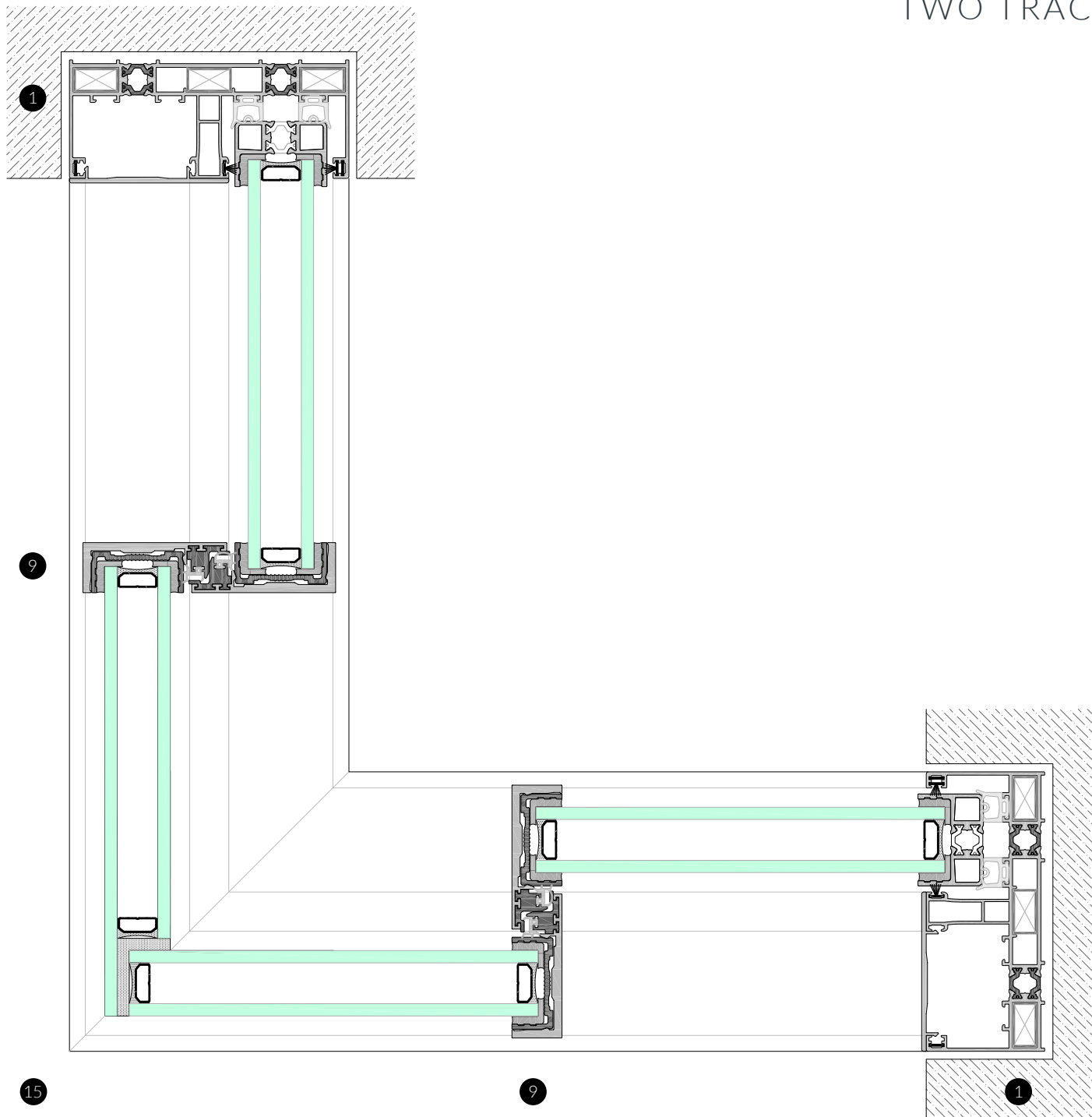

TWO TRACK OPEN CORNER FRAMES (SLIDING INSIDE)

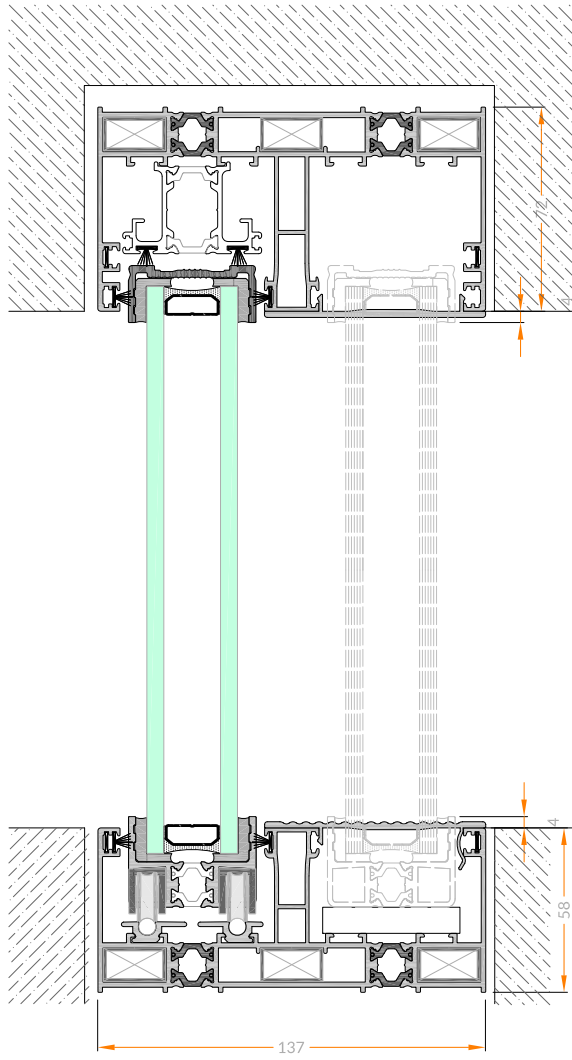

11.15

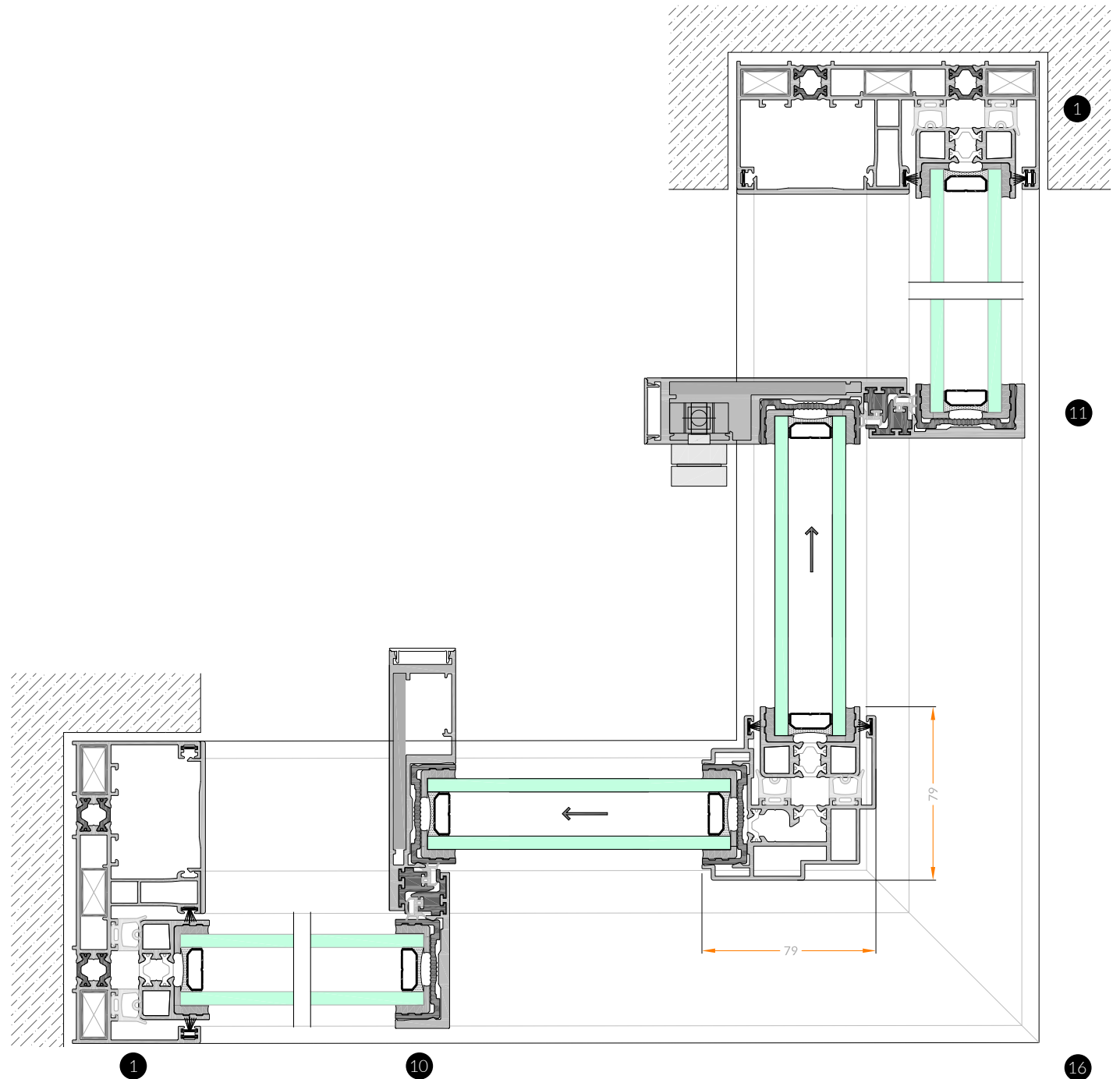
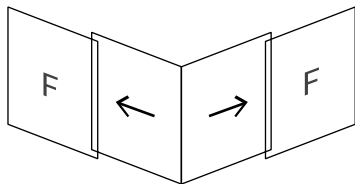

TWO TRACK OPEN CORNER FRAMES (SLIDING OUTSIDE)

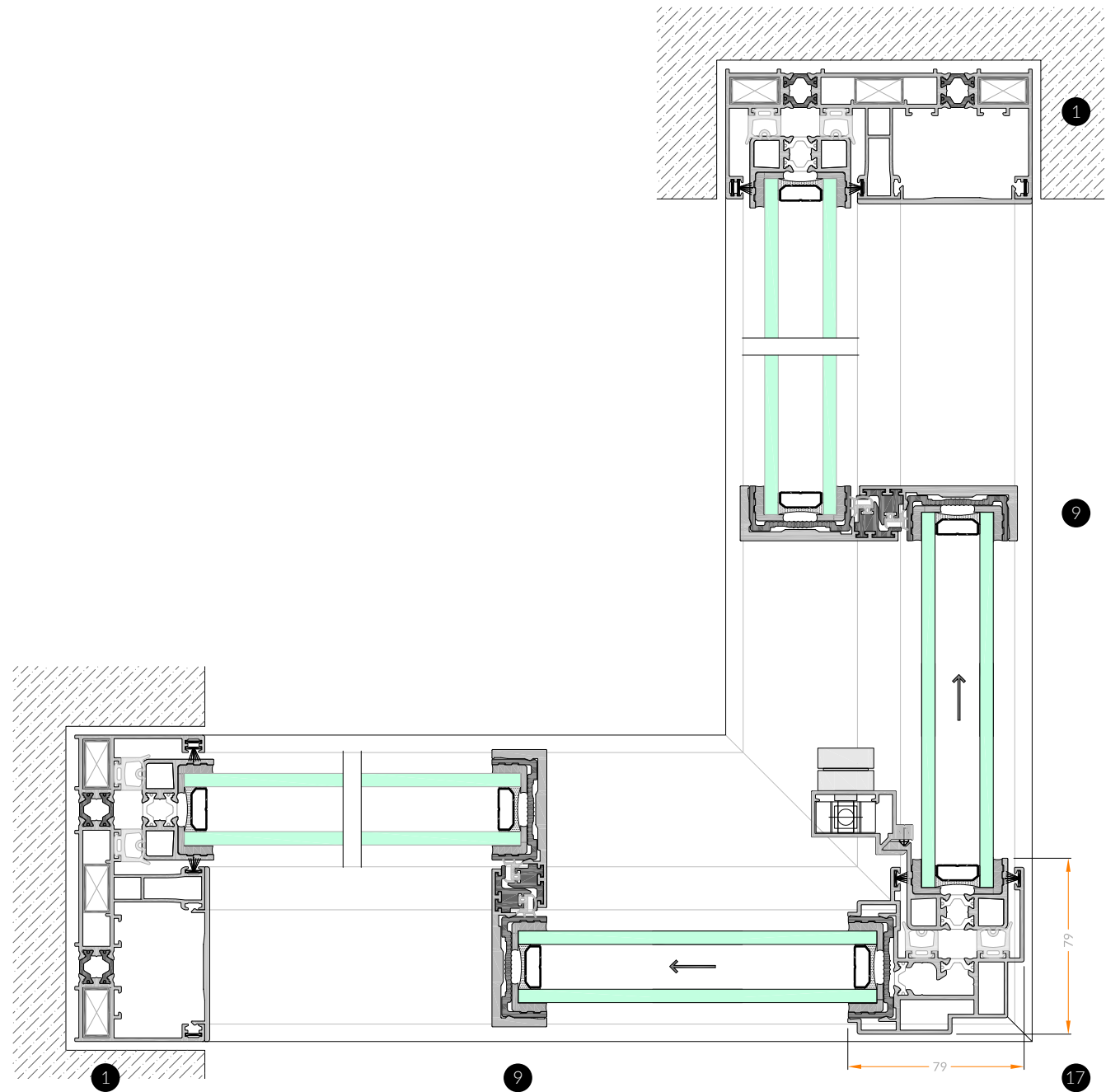
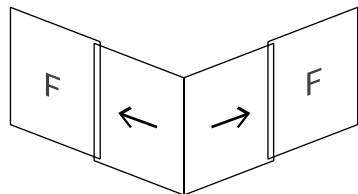
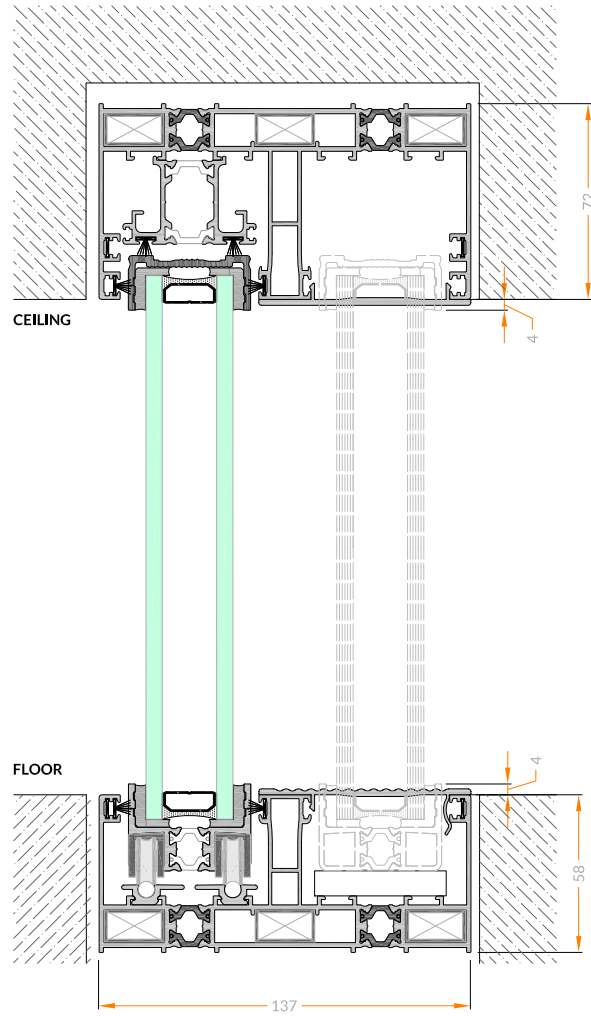

WIND LOAD DIAGRAMS

0,5
kN/m²

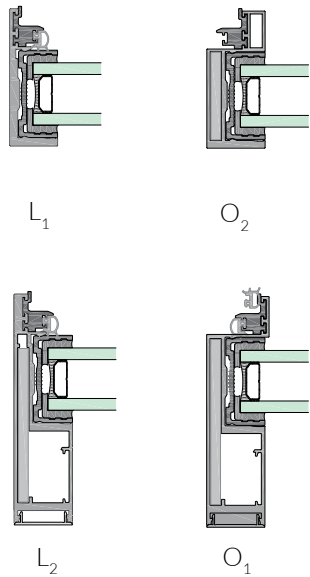
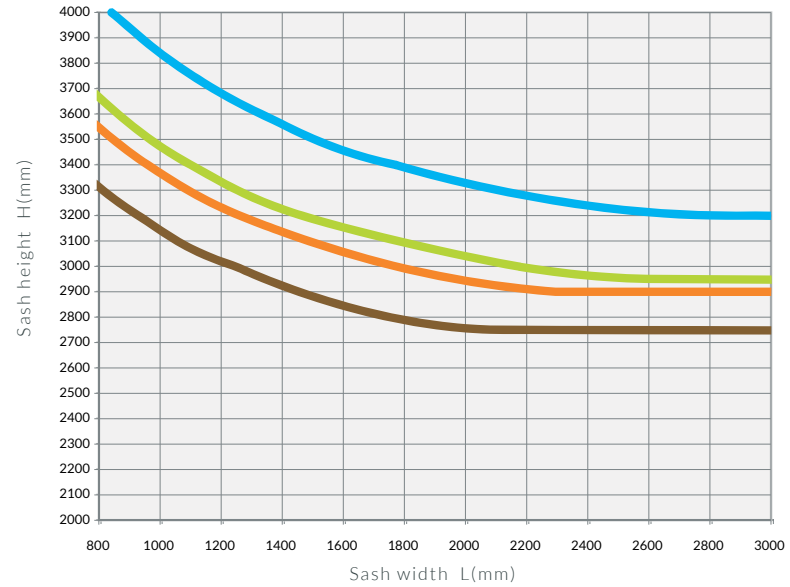
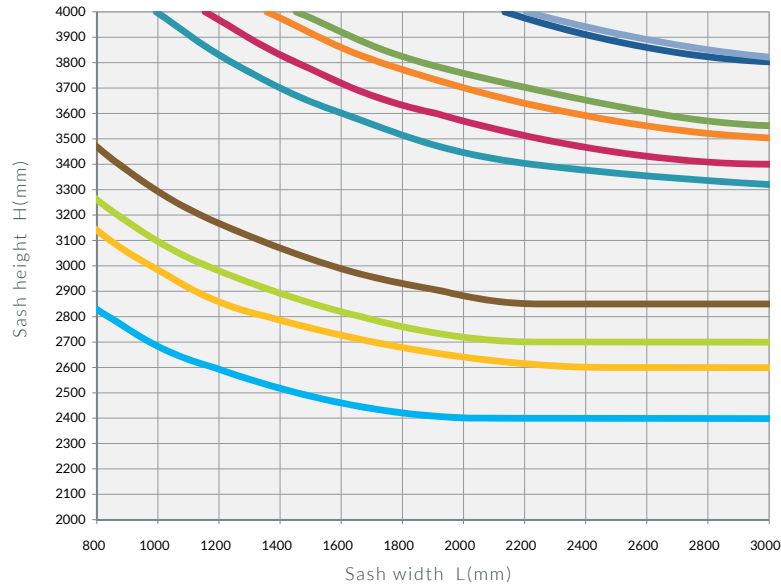

OMICRON

- O₁ + Steel reinf. —
- L₂ + Steel reinf. —
- L₂ —
- O₁ —
- L₂ + Alum. reinf. —
- O₂ —
- O₂ + Steel reinf. —
- O₂ + Alum. reinf. —
- O₁ + Alum. reinf. —
- L₁ —

- HA
- FA₁
- HB
- FA₂

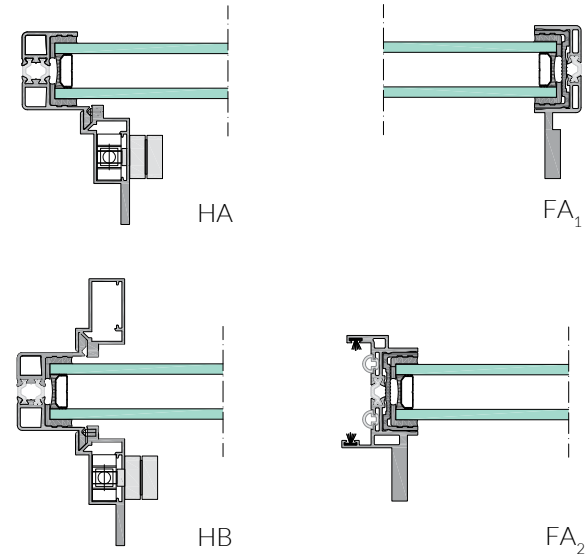





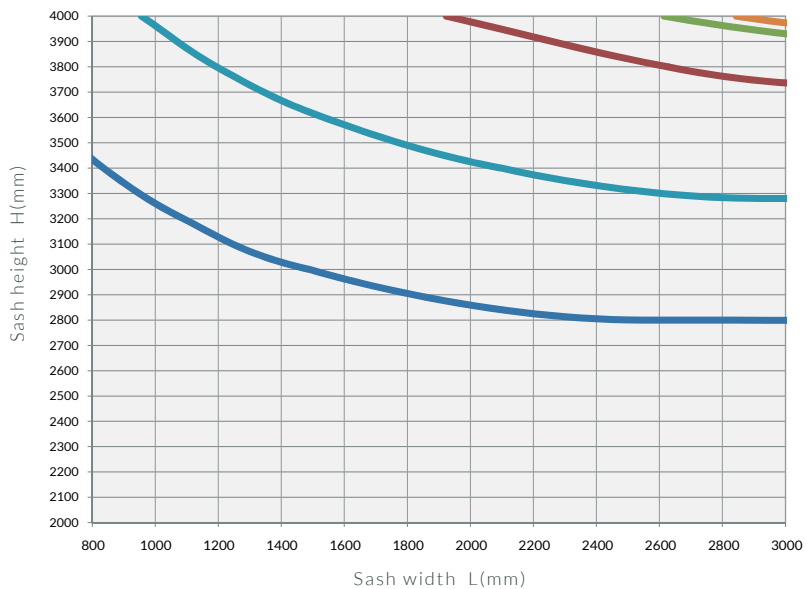

103
Km/h

WIND LOAD DIAGRAMS



ΩMEGA

-  D
-  C
-  B + Steel reinf.
-  B + Alum. reinf.
-  B
-  A

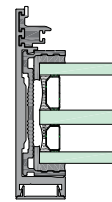

A

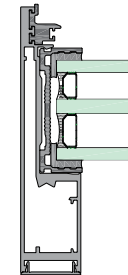

B

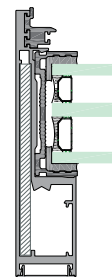

B + Alum. reinf.

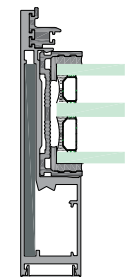

B + Steel reinf.

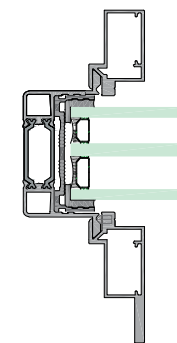
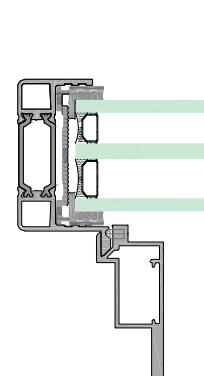

WIND LOAD DIAGRAMS

0,8
kN/m²

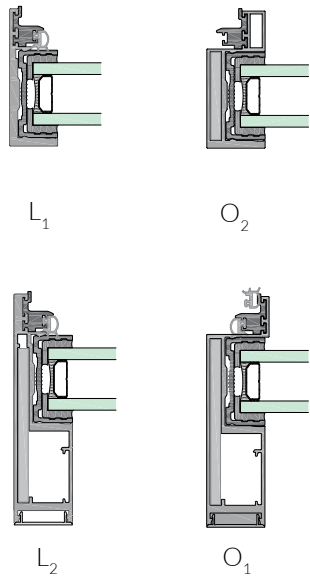
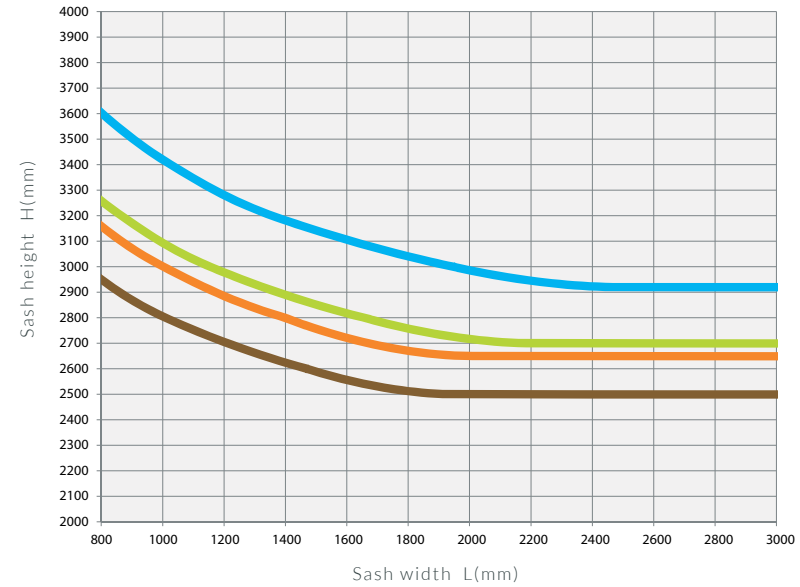
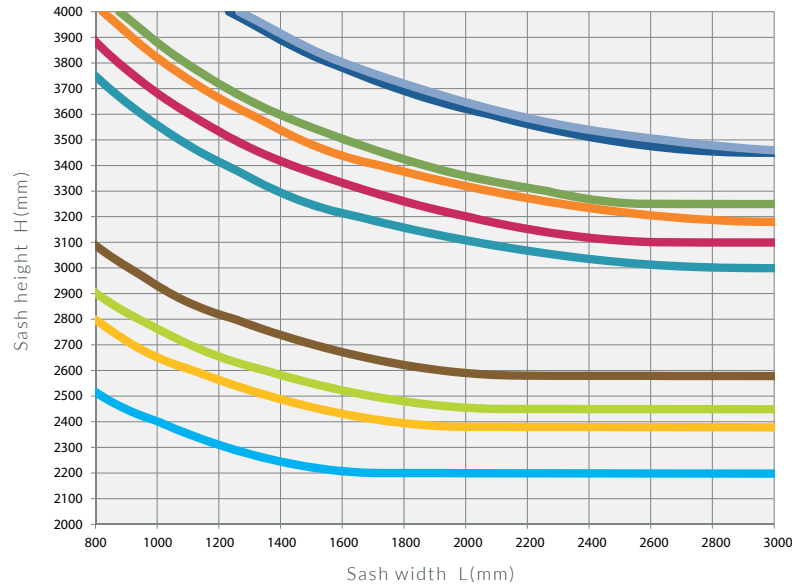

OMICRON

- O₁ + Steel reinf. —
- L₂ + Steel reinf. —
- L₂ —
- O₁ —
- L₂ + Alum. reinf. —
- O₂ —
- O₂ + Steel reinf. —
- O₂ + Alum. reinf. —
- O₁ + Alum. reinf. —
- L₁ —

HA

FA₁

HB

FA₂

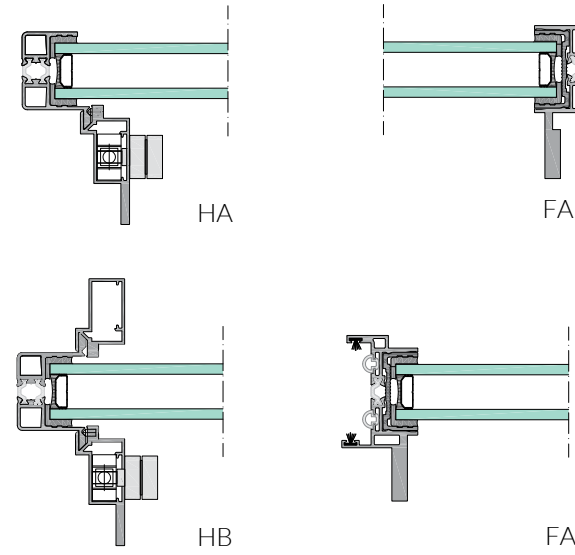





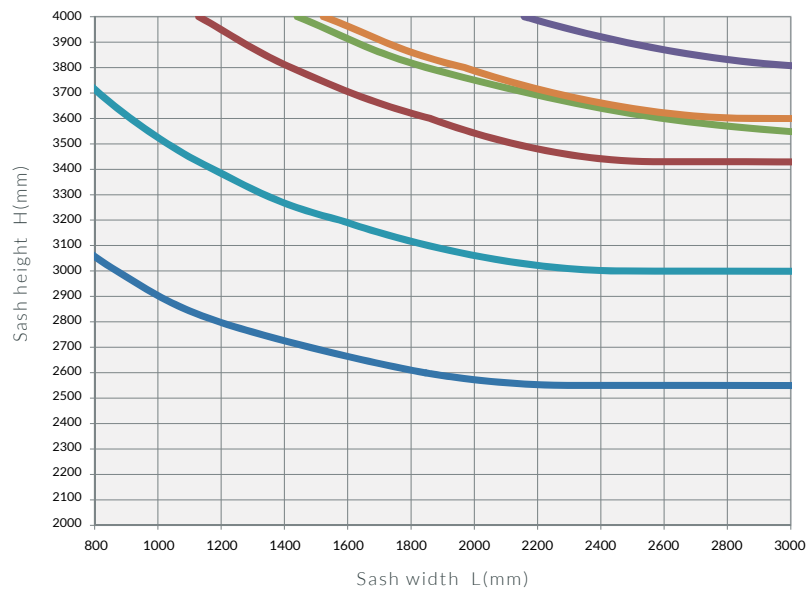

130
Km/h

WIND LOAD DIAGRAMS



ΩMEGA

-  D
-  C
-  B + Steel reinf.
-  B + Alum. reinf.
-  B
-  A

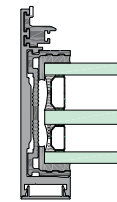

A

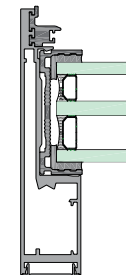

B

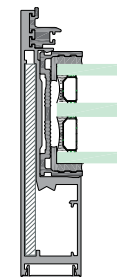

B + Alum. reinf.

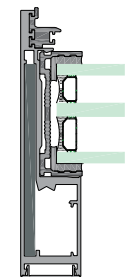

B + Steel reinf.

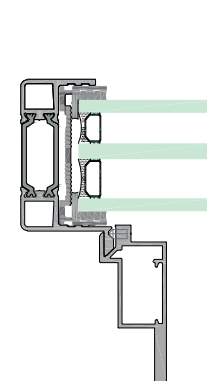

C

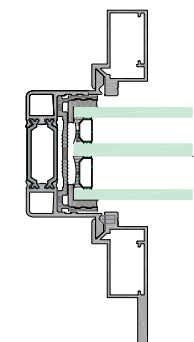

D

WIND LOAD DIAGRAMS

1,0
kN/m²

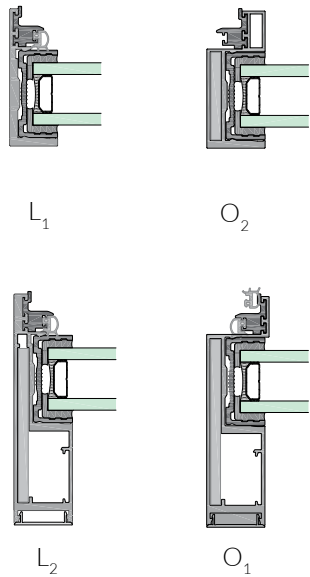
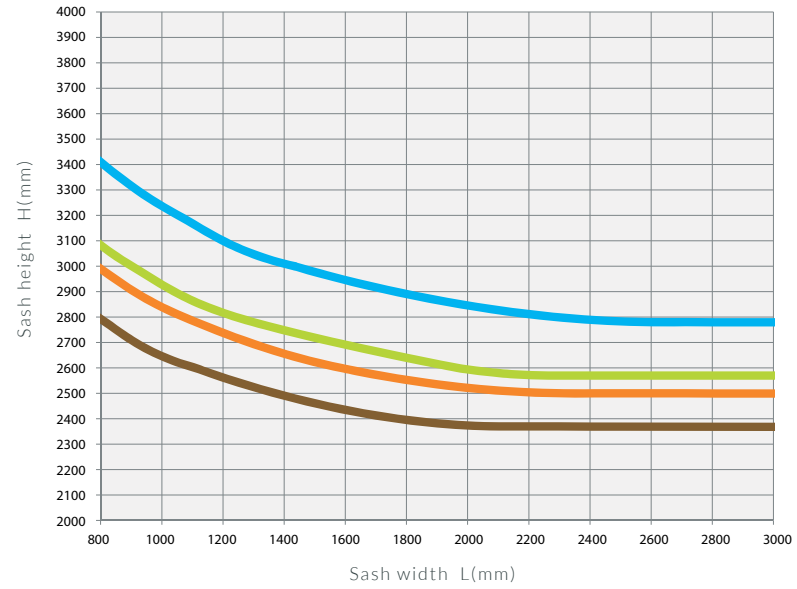
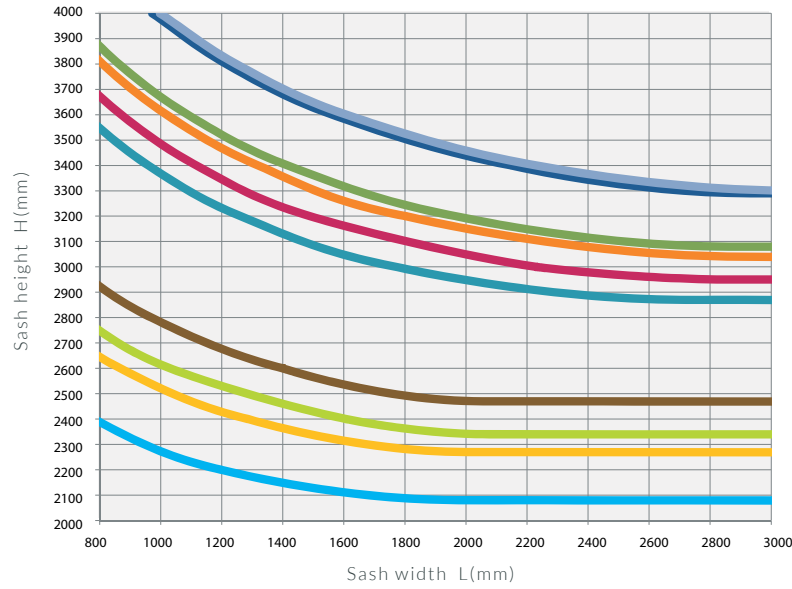

OMICRON

- O₁ + Steel reinf. —
- L₂ + Steel reinf. —
- L₂ —
- O₁ —
- L₂ + Alum. reinf. —
- O₂ —
- O₂ + Steel reinf. —
- O₂ + Alum. reinf. —
- O₁ + Alum. reinf. —
- L₁ —

- HA
- FA₁
- HB
- FA₂

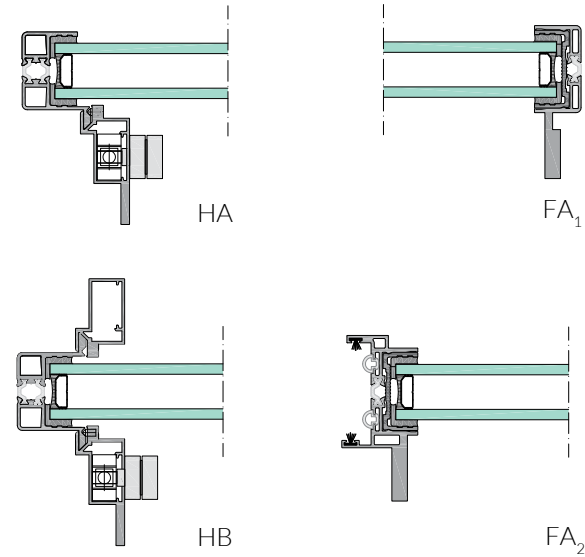





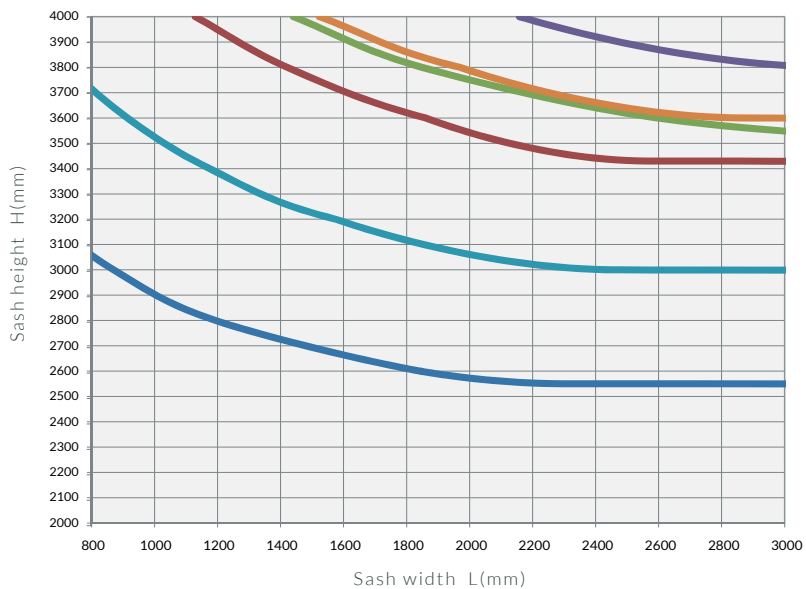

145
Km/h

WIND LOAD DIAGRAMS



ΩMEGA

-  D
-  C
-  B + Steel reinf.
-  B + Alum. reinf.
-  B
-  A

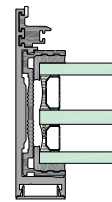

A

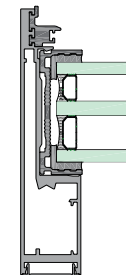

B

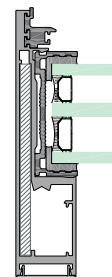

B + Alum. reinf.

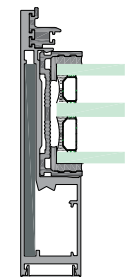

B + Steel reinf.

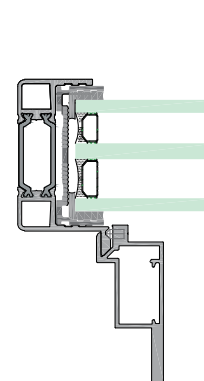

C

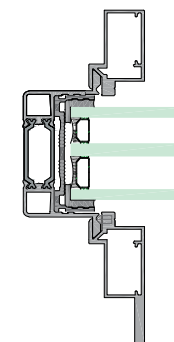

D

WIND LOAD DIAGRAMS

1,3
kN/m²

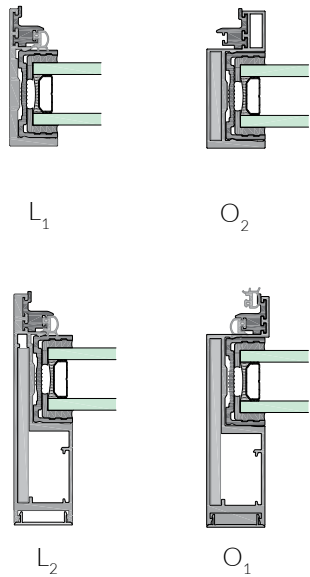
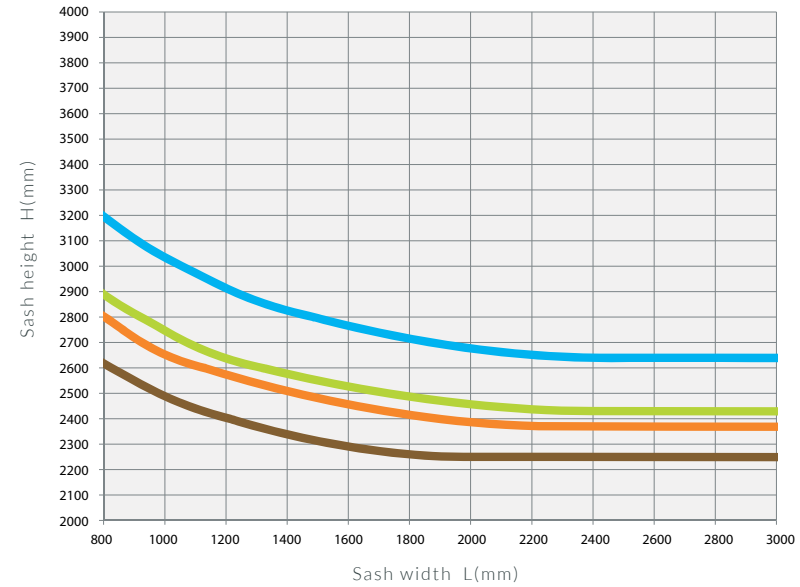
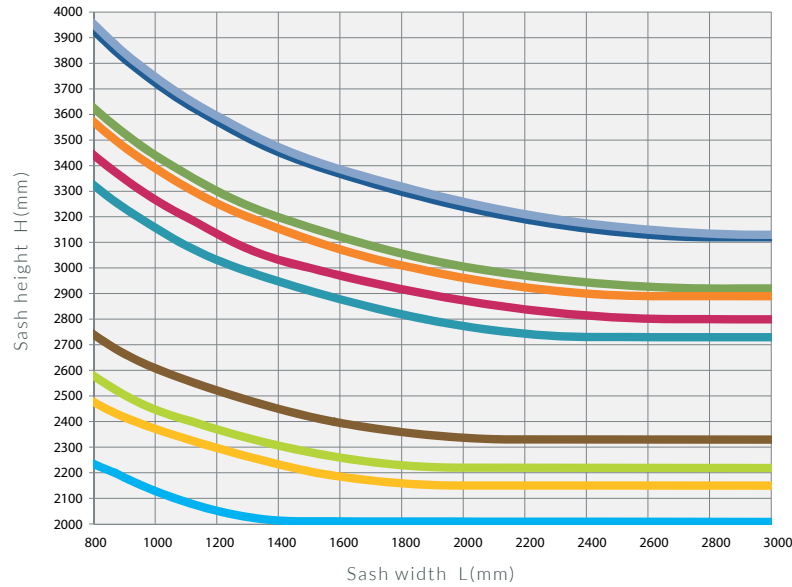

OMICRON

- O₁ + Steel reinf. —
- L₂ + Steel reinf. —
- L₂ —
- O₁ —
- L₂ + Alum. reinf. —
- O₂ —
- O₂ + Steel reinf. —
- O₂ + Alum. reinf. —
- O₁ + Alum. reinf. —
- L₁ —

HA

FA₁

HB

FA₂

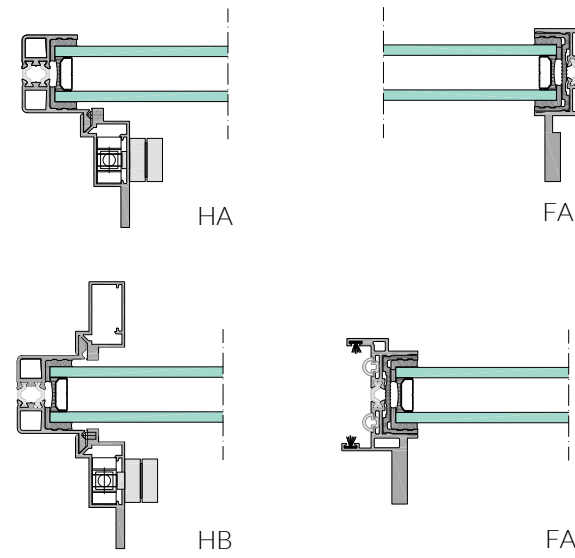

164
Km/h

WIND LOAD DIAGRAMS

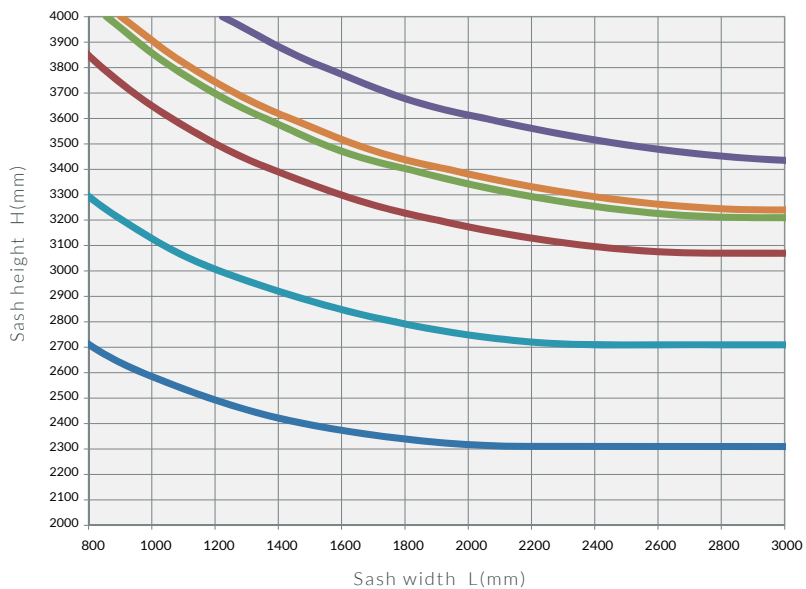

ΩMEGA

- D
- C
- B + Steel reinf.
- B + Alum. reinf.
- B
- A

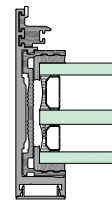

A

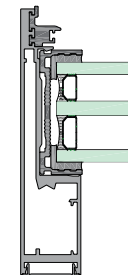

B

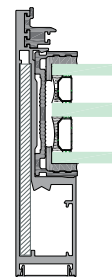

B + Alum. reinf.

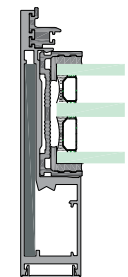

B + Steel reinf.

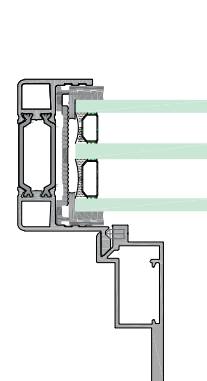

C

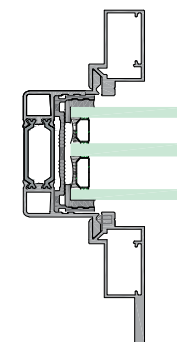

D

WIND LOAD DIAGRAMS

2,0
kN/m²

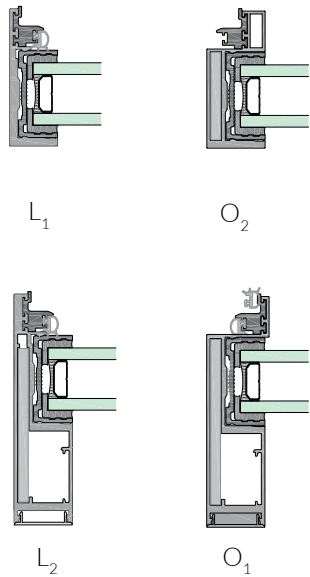
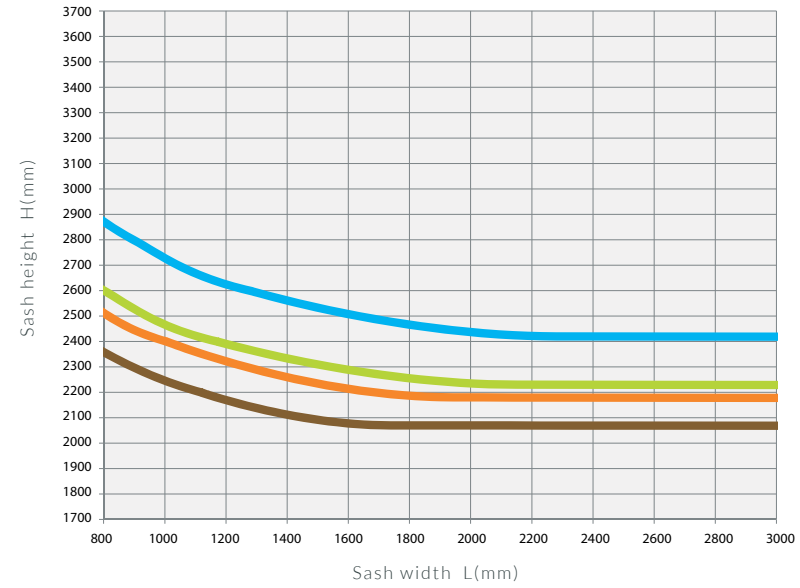
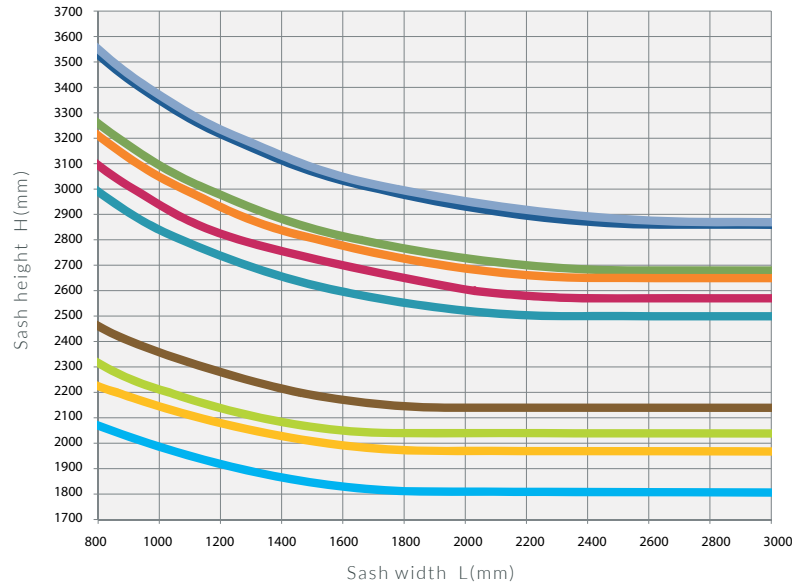

OMICRON

- O₁ + Steel reinf.
- L₂ + Steel reinf.
- L₂
- O₁
- L₂ + Alum. reinf.
- O₂
- O₂ + Steel reinf.
- O₂ + Alum. reinf.
- O₁ + Alum. reinf.
- L₁

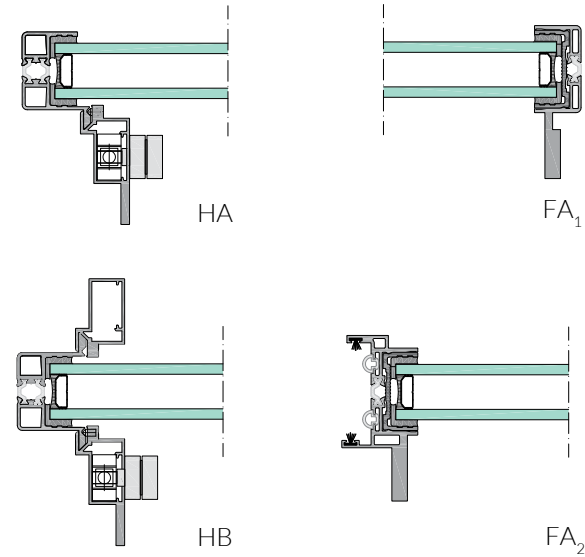

200
Km/h

WIND LOAD DIAGRAMS

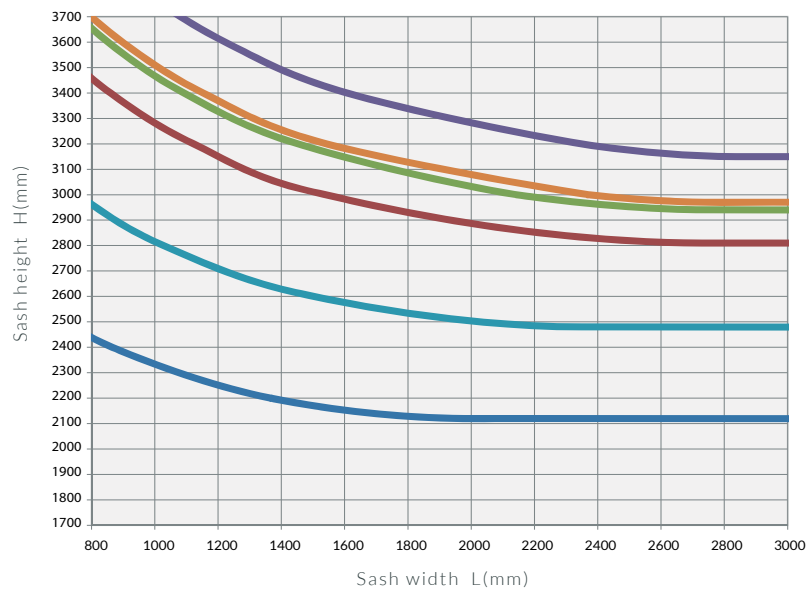

ΩMEGA

- D
- C
- B + Steel reinf.
- B + Alum. reinf.
- B
- A

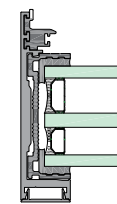

A

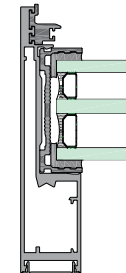

B

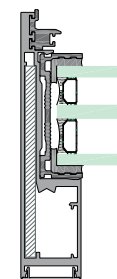

B + Alum. reinf.

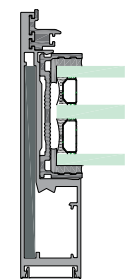

B + Steel reinf.

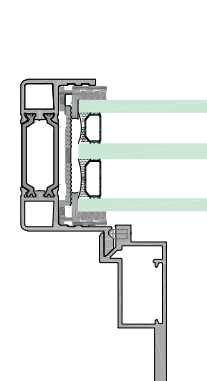

C

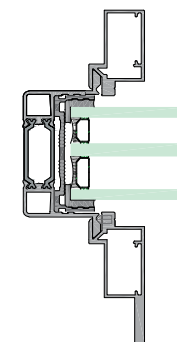

D

OMICRON • THERMAL PERFORMANCE

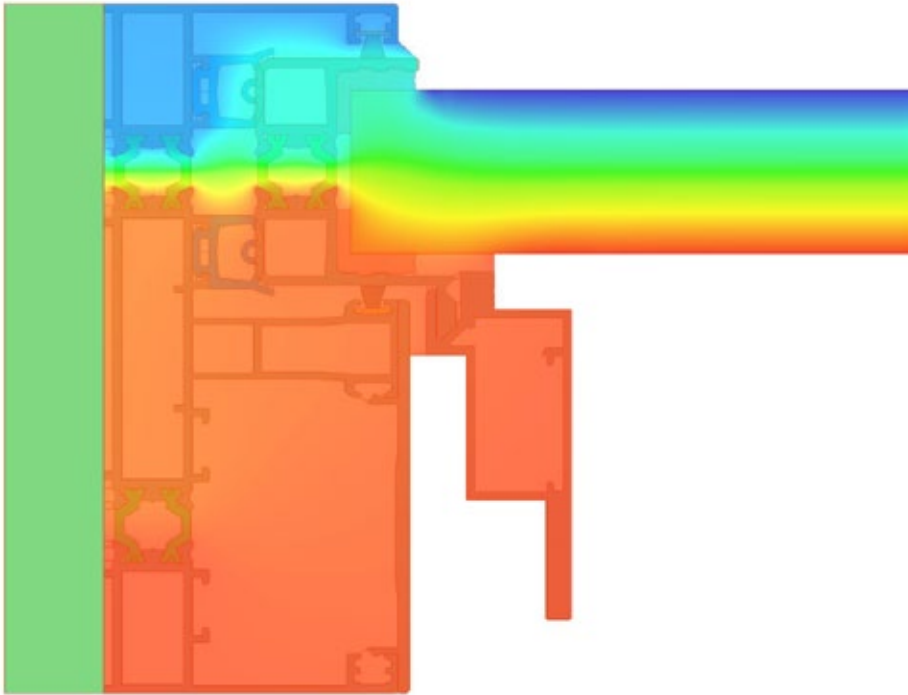

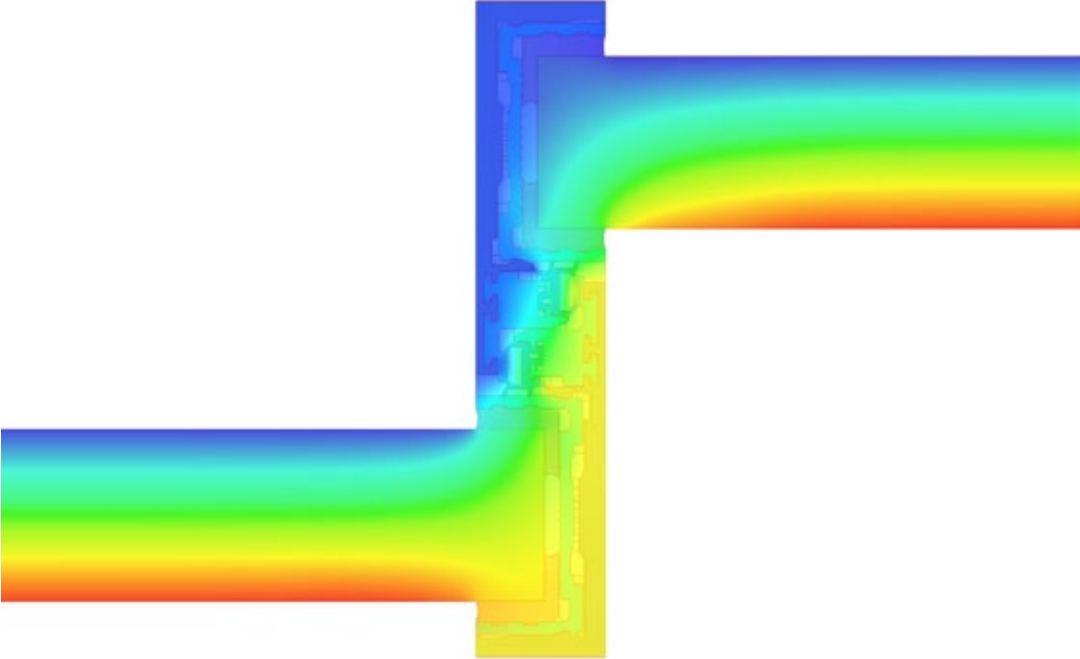

UW VALUES 0,7 - 1.7 W/M2K DEPENDING ON THE UG

